

HV  
3006  
V7A5  
1915a

# MENTAL DEFECTIVES

— IN —

# VIRGINIA

A Special Report of the STATE BOARD OF CHARITIES AND CORRECTIONS to the General Assembly of 1916, on Weak-Mindedness in the State of Virginia; together with a Plan for the Training, Segregation, and Prevention of the Procreation of the Feeble-Minded

RICHMOND

DAVIS BOTTUM, SUPERINTENDENT PUBLIC PRINTING

1916





Class HV3006

Book V7A5

1915a













JAMES Z. AND FAMILY.



# Mental Defectives in Virginia

A SPECIAL REPORT

52  
1833

OF THE

State Board of Charities and Corrections

TO THE

General Assembly of Nineteen Sixteen

ON

WEAK-MINDEDNESS *in the* STATE OF VIRGINIA

*Together with a Plan for Training, Segregation and  
Prevention of the Procreation of the Feeble-minded*

---

RICHMOND:

DAVIS BOTTOM, SUPERINTENDENT PUBLIC PRINTING









1915

*State of Virginia*  
187

## Table of Contents

LETTER OF TRANSMITTAL TO THE GOVERNOR OF VIRGINIA.....	3-7
I. GENERAL INTRODUCTION .....	8-11
II. REPORT OF VISIT TO INSTITUTIONS .....	12-17
III. THE RELATION OF HEREDITY TO FEEBLE-MINDEDNESS.....	18-22
IV. THE RELATION OF FEEBLE-MINDEDNESS TO INSANITY.....	23-30
V. THE RELATION OF FEEBLE-MINDEDNESS TO EPILEPSY.....	31-38
VI. THE RELATION OF FEEBLE-MINDEDNESS TO PAUPERISM.....	39-58
VII. THE RELATION OF FEEBLE-MINDEDNESS TO JUVENILE DELIN- QUENCY .....	59-64
VIII. THE RELATION OF FEEBLE-MINDEDNESS TO PROSTITUTION.....	65-71
IX. THE RELATION OF FEEBLE-MINDEDNESS TO CRIME AND DRUNK- ENNESS .....	72-109
X. SUMMARY .....	110-112
XI. A PLAN FOR THE TRAINING, SEGREGATION AND PREVENTION OF THE PROCREATION OF THE FEEBLE-MINDED.....	113-119
APPENDIX—THE PUBLIC SCHOOL AND THE ABNORMAL CHILD....	120-128

### EXPLANATION OF SYMBOLS.

Male	Female	
		<i>Feeble-minded.</i>
		<i>Normal.</i>
		<i>Mentality Undetermined.</i>
		<i>Miscarriage, or Still Birth.</i>
 d. inf.		<i>Died in infancy.</i>

### LETTERS, &c., USED IN AND AROUND SQUARES AND CIRCLES.

A Alcoholic—a Drunkard.	Ne. Neurotic.	Tb. Tuberculous.
C Criminalistic.	Sy. Syphilitic.	 In an institution.
E Epileptic.	Sx. Sexually Immoral.	? Implies doubt.
I Insane.		

A horizontal (or oblique) line connects persons who are legally mated. Symbols dependent from the same horizontal line show brothers and sisters.

A vertical line connecting this horizontal line with an individual or with a line connecting two individuals, indicates the parent or parents of the fraternity.

When the parents are not married the fact is indicated by a dotted line connecting two symbols.





For five years, by direction of the General Assembly, this Board has been studying feeble-mindedness in Virginia. It was felt that in order to complete this study it was necessary to bring to the attention of our lawmakers the part feeble-mindedness plays in the production of those forms of degeneracy which constitute the greatest menace to social advancement, and to suggest a method of reducing this menace. Hence the following law was enacted:

1. Be it enacted by the General Assembly of Virginia, That the State Board of Charities and Corrections be, and it is, hereby authorized and directed to continue the investigation of the question of the weak-minded in the State, other than insane and epileptic, and to report to the General Assembly of nineteen hundred and sixteen a comprehensive, practical scheme for the training, segregation and the prevention of the procreation of mental defectives.

The said Board is hereby authorized and empowered in its discretion to employ such experts as may be found needful to assist in the work above outlined.

Pursuant to this act, the State Board of Charities and Corrections determined,

1. To investigate the relation of feeble-mindedness to insanity and epilepsy, to juvenile delinquency, to crime, to pauperism and prostitution, in order to show the possibility of reducing these forms of degeneracy with the consequent tremendous expense through the elimination of mental defectiveness.

2. To study the methods now in use, for the prevention of feeble-mindedness, in the best institutions of this country.

Much useful information had already been gathered, and a mass of valuable material was on file in this office. The work here reported consists largely in verifying, formulating and drawing conclusions from material already in hand, and in following out lines of investigation already begun.

The corps of investigators employed to work one year under the direction of this board were Miss Elizabeth E. Webb (now Mrs. William Blakey), Miss Ella V. Ball, and Mr. Harvie D. Coghill.

Mrs. Blakey is a graduate of Vineland, N. J., summer training school, and subsequently spent a year and a half at the Vineland institution where she received special instruction in the biological and pathological departments under Drs. A. W. Peters and W. J. Hickson, and in research under Dr. H. H. Goddard. Mrs. Blakey was employed by the school board of Richmond during the session of 1913-14, when she made an investigation into the mental condition of backward children, and assisted in the organization of special classes for such children. As to her efficiency, Professor E. R. Johnstone, superintendent of the training school at Vineland, N. J., writes:

"I neglected to write you regarding Miss Webb's qualifications. She was for one year a student in our laboratory, and took two summer courses here—the second year she was assisting Dr. Goddard with the laboratory work in the training of teachers. We consider



her indeed very well qualified for the work suggested. I believe that she will do excellent work; you or any one taking her services will be much pleased with the results."

Miss Ball is a B. A. of Randolph-Macon Woman's College, where she specialized in sociology. She holds a certificate of graduation from the summer training school at Vineland, N. J., and has taken the training course given by the Federated Charities of Baltimore, Md. She has done settlement work in Richmond.

Mr. Coghill was for seven years a successful business man in Virginia, meanwhile devoting attention to the study of sociology. He resigned to pursue studies at Richmond College, specializing in English, French and psychology. Afterwards he studied sociology in Europe, and visited many of the large European prisons. Last year he was employed in the juvenile court of Richmond as acting probation officer, chief record clerk and investigator. Mr. Coghill has likewise done some newspaper and magazine work, and is a foundation member of the literary group of the Fresh Air Art Society of London and a member of a French society for scientific research.

The secretary has also given the greater portion of his time during the year to this investigation, and Drs. A. S. Priddy and W. F. Drewry were requested to co-operate. Under the direction of Dr. Priddy, Mrs. Blakey was employed several weeks at the Epileptic Colony and the Colony for the Feeble-Minded. She also worked under Dr. J. C. King at the Southwestern State Hospital, and under Dr. W. F. Drewry at the Central State Hospital, and she investigated two degenerate families, one in the mountains and the other in the Tidewater section of the State. In addition, Dr. Drewry and the secretary studied a group of the best institutions in this country, and interviewed many of our leading specialists in mental defectiveness. An account of these studies appears in the report.

Although in our investigations the Binet-Simon Measuring Scale for Intelligence was extensively used, we by no means depended upon it exclusively. The major portion of Miss Ball's time was expended in conducting investigations into the family, economic, social and school history of those the test indicated as feeble-minded. Mr. Coghill spent six months in a critical study of our prison population and our jail system, and the employees of the board have all devoted part of their time to a study of the life history of defectives.

We have ventured to treat at greater length the subjects of crime and pauperism, because the feeble-minded when brought to the attention of the legal authorities are usually classed as criminals or paupers. The jail and almshouse are, therefore, the institutions where a large proportion of mental defectives find refuge.

In this report a very small portion of the material gathered during the investigation is published; to print it all would make the report too long. Moreover, the board was reluctant to place before the public the record of these pitiful lives. A sense of loyalty to the truth, however, compels the publishing of a sufficient amount of the great mass of sorrowful material laid away in our files, to enable the reader to form a mental picture of conditions as they actually exist in Virginia.

It should be borne in mind that much of the material used the board has been gathering for five or six years, and that this material has been verified, tested, and put in shape by specialists during the year. For instance: During her vacation in 1914, Mrs. Blakey was employed by the Men's League of St. Paul's Episcopal Church, Richmond, to test by the Binet-Simon Measuring Scale the women in the Red-Light District of the City of Richmond. One hundred and twenty of these women were subjected to the test. The Men's League kindly allowed the board to use Mrs. Blakey's report in this investigation. It has been carefully revised, and the family, economic, social and school history of as many as possible of the women has been studied. The secretary is a member of the investigating committee of the vice commission of Richmond, and was afforded by his position an exceptionally good opportunity to study the district. In addition, when the district was closed, the secretary had charge of the work of assisting the women who were destitute, and about one hundred of them were brought in touch with our office, and with a group of social workers of the city, who aided in the relief work. These observations and investigations confirm the results of the Binet test.

Among the colored children committed to this board by the courts, there are many who, according to the Binet test, are feeble-minded. The Negro Reformatory is always overcrowded. The alternative, therefore, has been to place these children in carefully selected family homes, or to allow them to go to jail to serve a short sentence, and then return to the bad environment from which they had been taken. We chose to place them in homes. The family history of the children we obtain where possible. Some of them we have had under observation for two or three years. They have been visited by our agents, and we have secured semi-annual reports from the persons in whose homes they are located. These are the children upon whose records we have based, in part, the paper on Juvenile Delinquency, which is made a part of this report. We have likewise carefully studied three or four hundred white children who have been brought into the juvenile courts.

Nothing in this report has been written in criticism of officials. The persons in charge of our institutions should not be blamed for the evils resulting from a bad system. We have recorded the facts as they appear to us, not in any spirit of criticism, but in order that our people may know the truth, and, acting upon it, may be delivered of a grievous burden which, if left alone, will increase with the years until it becomes too heavy to be borne.

The bills relating to the feeble-minded, which we will suggest that the General Assembly enact into laws, are now being prepared by Hon. Lewis H. Machen, of the Legislative Reference Bureau.

In the preparation of this report we have studied the reports of all the institutions for anti-social classes that we could obtain. We have likewise made use of the report of the Royal Commission for the Study of Mental Deficiency of Great Britain. We are especially indebted to Professor E. R. Johnstone, Mr. Alexander Johnson, and Dr. H. H. Goddard, of the Training School at Vineland, N. J.; to Dr. Walter E. Fernald, of the Institution for

the Feeble-Minded at Waverly, Mass.; and to Messrs. John Glenn and H. H. Hart, of the Russell Sage Foundation, and to Dr. Walter S. Cornell, director of medical inspection of the public schools of Philadelphia, Pa., and Mr. W. H. Whittaker, superintendent of the District of Columbia Workhouse.

Yours very respectfully,

S. C. HATCHER,  
*Chairman.*

# Chapter I.

## The General Introduction.

There will be found in this report the results of a study made pursuant to an act of the General Assembly of 1914, for the purpose of suggesting a plan for the training, segregation, and prevention of the procreation of the weak-minded.

The term "weak-minded" was doubtless employed instead of the usual designation "feeble-minded," because it was intended to broaden the scope of this investigation to include other anti-social classes not strictly covered by the technical term "feeble-minded." In other words, there was in the minds of the originators of the investigation the purpose to find, if possible, a more reasonable, humane, and economical method of dealing with the manifold manifestations of mental degeneracy (other than insanity and epilepsy) than that at present in use in the Commonwealth.

Accordingly, while it has been found necessary to employ in this report the term "feeble-minded" more frequently than any other because the classes dealt with are nearly all mental defectives, it must be borne in mind that however widely we may differ in our opinions as to the efficiency of tests, or in our views with regard to generally accepted definitions and classifications, we must agree that there is a large percentage of our population which, though never having been declared insane or epileptic, is nevertheless permanently, expensively, and often dangerously anti-social. It is equally plain to all who have given the subject thought that lack of attention to this element of our population has resulted in increasing social degeneracy with consequent tremendous social and economic loss. These, then, are the people with whom this report concerns itself.

In view of the fact that Virginia is not classed among the wealthy States, the Board of Charities has had constantly before it in the prosecution of this work the question: *Is it not possible to devise a less expensive plan than that at present in use?*

The annual cost of the present method of dealing with our anti-social classes other than insane and epileptic (as nearly as can be ascertained) is as follows:

Aggregate criminal charges .....	\$ 440,528 43
Aggregate expense of paupers (almshouses and out-door relief) .....	462,010 88
Expense to churches and to charitable organizations of maintaining poor in the State (estimated) .....	2,000,000 00
	<hr/>
	\$2,902,539 31

The appalling thing is not the cost per annum of maintaining the anti-social classes, but that the present plan, expensive as it is, is only palliative

—it temporarily mitigates to a small degree, but does not, nor can it ever cure the evils it attempts to cope with—and it not only cannot cure them, but it is actually encouraging the anti-social classes to continue in their anti-social habits; it educates in crime the beginner in delinquency; it tends to make of the jail prisoner a repeater; it pauperizes the impoverished; it encourages the procreation of the feeble-minded; it fills the almshouses with mentally defective folk who are allowed to bring into the world feeble-minded children who will in turn populate the almshouses and jails of coming generations: year after year it is not only costing the taxpayer heavily, but it is piling up a gigantic debt for future generations to pay.

It is the purpose of this report to endeavor to show not only that our present plan of dealing with the anti-social classes is ineffectual, but to show just where it fails in the various institutions to meet the social needs.

*Feeble-Mindedness Defined.*

Feeble-mindedness is defined as a “state of mental defect existing from birth or from an early age and due to incomplete or abnormal mental development in consequence of which, the person affected is incapable of performing his duties as a member of society in the position of life to which he is born.”

The Royal Commission of England defines the high-grade feeble-minded as “One who is capable of earning his living under favorable circumstances, but is *incapable* from mental defect existing from birth or from an early age of competing on equal terms with his normal fellows or of managing himself and his affairs with ordinary prudence.”

Tredgold declares that an essential function of the mind is ability to maintain existence; absence of this constitutes abnormality, and he gives the following definition: “Arrest of cerebral development in consequence of which the person affected is incapable at maturity of so adapting himself to his environment or to the requirements of the community as to maintain existence independently of external support.”

Prof. E. R. Johnstone, of Vineland, N. J., gives the following classifications of the feeble-minded from the standpoint of industrial ability:

IDIOT.....*Low-Grade*; an adult with the mentality of a normal child under one year old; helpless.

*Middle-Grade*; an adult with mentality of normal child one year old; feeds self anything.

*High-Grade*; adult with mentality of normal child two years old; eats discriminatingly.

IMBECILE...*Low-Grade*; an adult with mentality of normal child three or four years old; plays a little; tries to help.

*Middle-Grade*; an adult with mentality of normal child five years old; can perform only the simplest tasks.

*High-Grade*; an adult with mentality of normal child six or seven years old; can do little house errands such as washing dishes and dusting.



**MORON**.....*Low-Grade*; an adult with mentality of normal child eight or nine years old; can scrub, mend, care for room, make bed, etc.

*Middle-Grade*; an adult with mentality of child ten years old; can do regular work; uses tools.

*High-Grade*; an adult with mentality of child eleven or twelve years old; can do complicated work such as caring for animals, using machinery, but cannot plan.

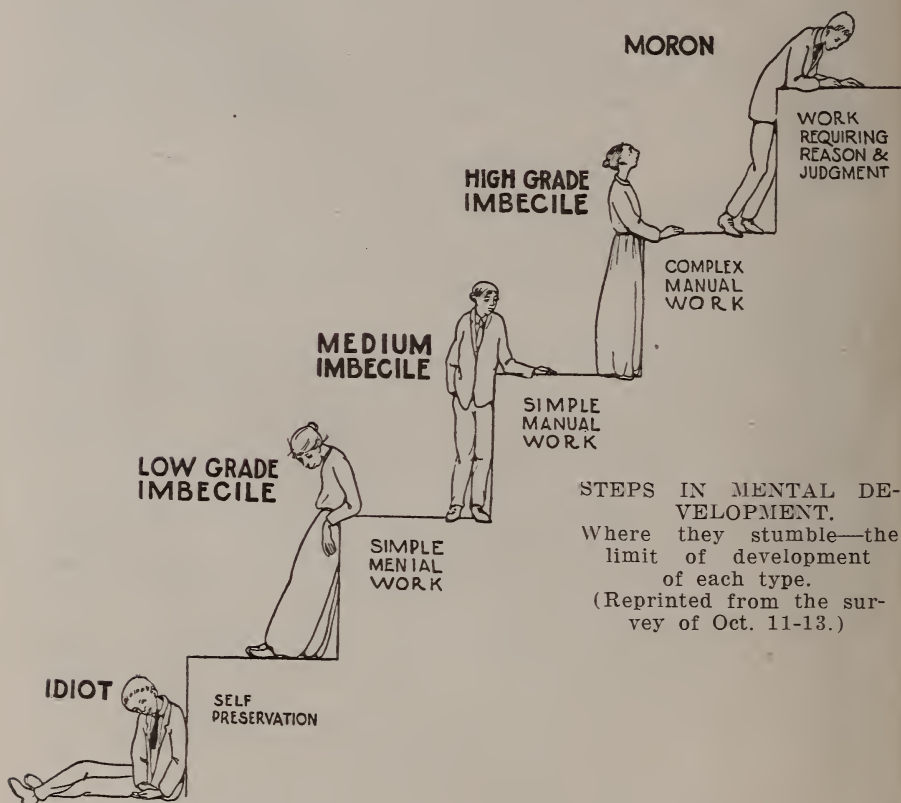

*The Binet-Simon Measuring Scale for Intelligence.*

This Scale, which was originated about twelve years ago by Binet and Simon, two celebrated French psychologists, consists of a series of graded questions, or tests, by which mental development may be measured. It was standardized by Binet on the children of the middle class of France, and when introduced in the United States, was adapted for American use by Dr. H. H. Goddard, of Vineland, N. J.

Dr. Goddard says of the Scale: "No one should be surprised that the Binet-Simon Measuring Scale for Intelligence has met with criticism and

opposition. It is doubtful if even its most ardent advocates read it over for the first time without feeling that it must be impossible for such a scale to be reliable; and it is only after repeated trials and continual discovery of the accuracy with which it reveals the facts that one becomes convinced that it is not only of value, but of such remarkable accuracy that it supersedes everything else. So rapidly has this conviction spread, and so widely has it extended, that now those who are familiar with the tests have become so entirely confident of their supreme merit that the criticisms that from time to time appear only arouse a smile and a feeling akin to that which the physician would have for one who might launch a tirade against the value of the clinical thermometer."

Dr. Frank Moore, superintendent of the New Jersey Reformatory for Men, uses the Binet scale, but does not consider it infallible, and does not depend upon it alone.

Dr. Walter E. Fernald, of Waverly, Mass, uses in his institution the Binet scale; and in addition, a study is made of the family history, school history, economic efficiency, moral reactions, and personal knowledge of the subject. If three of these show subnormality below the accepted standard, the pupil is considered feeble-minded.

In the use of the Binet-Simon Measuring Scale for Intelligence in this investigation, we have classified as feeble-minded all children who have reacted more than three years backward, and all adults who have tested less than twelve years mentally, provided three of the supplementary tests (as used by Dr. Fernald) confirmed the reactions of the psychological test.

## Chapter II.

### Report of visits to Institutions for Mental Defectives, September, 1914.

The object of this tour of inspection was (1) to study the menace of the feeble-minded, and (2) the methods in use for dealing with (a) the prevention of mental defectiveness, and (b) care and maintenance, and the economic efficiency of the feeble-minded. Fifteen institutions were visited and studied, and much valuable data was collected, the gist of which is presented in this paper.

#### *The Menace of the Feeble-Minded.*

The civilized nations of the earth are awakening to the menace of the feeble-minded, and there is now universal interest in the world-wide investigation of this problem. In England a Royal Commission has been at work studying the question for the past ten years, and the work at Vineland and Waverly in our country has attracted the attention of all enlightened peoples. Special investigations are being conducted at public expense in New York, Pennsylvania, New Jersey, Massachusetts, Michigan, Indiana, Ohio, Minnesota, and Virginia. All of the institutions visited were studying the question.

The high-grade imbecile and the moron constitute one of our most serious social problems. These people have none of the stigmata of the lower grade of mental deficient, and are not as easily recognized as the idiot and low-grade imbecile. They often talk fluently, and many of them have good memories. As every one acquainted with psychology knows, the mind is composed of intelligence, emotions, and will; consequently, a person may show normal intelligence by a test applied to ascertain intelligence, and still that person may not have emotional control, and may be so weak of will as to be unable to resist ordinary temptations, and is therefore weak-minded. But as a rule, persons testing normal by the Binet-Simon scale are classed as normal, unless their moral, social, family, and school history prove them to be otherwise. As to memory, there are some remarkable instances in the institutions visited. For example, a girl at Waverly, six years old mentally, can give from memory the name of every girl in the building. Physically, some morons possess a remarkable degree of attraction; for instance, at one institution we were shown a beautiful girl in the bloom of young womanhood. She appeared to be normal, but was really only nine years old mentally. Her father is in the penitentiary, a sister in the reformatory, and she has a brother who is a "rough-neck" imbecile now in the reformatory for assaulting little girls.

While the moron and the high-grade imbecile appear not to be more ignorant or silly than their associates, they lack ability to adapt themselves to their environment, and "cannot maintain existence independently of external support," they cannot manage their affairs with ordinary pru-



dence; they cannot overcome the temptations common to normal persons—to them the easiest way to get rid of a temptation is to yield to it.

In all institutions for the feeble-minded these high-grades are being studied. There, they are trained under ideal conditions and by the best methods. The result is always the same—their minds will not grow, they do not advance mentally. For instance, we saw at Vineland a young man twenty years old tested with the Binet-Simon Scale. It was the fourth time he had been tested at intervals of six months; each test showed practically the same result. His mental age was between seven and eight years. In his case two years' training, while it has doubtless improved him industrially, has not caused him to grow mentally. The doctor said: "He is all right here, but out in the world he could easily be led to commit murder or any other crime."

Dr. Goddard, in giving an account of the results of the study of 327 cases, says:

"Although every effort born of blind devotion to an ideal has been made to make these children normal or at least relatively high-grade, it has invariably failed, and they have learned nothing that is beyond their mental age."

And so it is in every case. They will not advance mentally. They cannot. Everywhere there is a line drawn marking a degree of intelligence to which these persons cannot reach. They will inevitably fall by the way-side unless some stronger hand give them aid.

What accentuates the problem, however, is that many of the high-grade are sexual perverts and criminals. In the female you find a mind seven to ten years with a weak will in the body of an adult, 17 to 30 years of age, fully developed sexually, and once she goes wrong, passion-driven, she is difficult to control ever after. As with the female, so with the male, only the former constitutes the greater menace. A superintendent pointed out a group of women aged mentally from seven to eleven (typical of some of the girls at the Virginia Home and Industrial School for Girls). He declared they were the most difficult to control in the institution, and every one of them had had children—from one to three children each. At a leading institution the only building we saw with bars on the windows are the one in which mentally defective, sexually immoral women were confined.

The feeble-minded in special institutions for this class were not the only ones we found on our tour. We saw them in the reformatories also. At the New Jersey Reformatory, Dr. Moore informed us that one-third of the inmates were feeble-minded; that this has been ascertained not by guess, but by actual scientific tests, the accuracy of which has been fully proved. He added: "Though the law says that no offender shall be admitted who is under 16 years of age, and although, too, the average of all is 21, yet 33% are below 12 years mentally, and some have been received who are not half that old. They are not only deficient in knowledge and ability to learn, but they are so weak in will that when they are out from under the control of those who would do them good, they are easily led by those who are designing to do almost any crime."

But the worst phase of the menace of the feeble-minded is not merely the danger from the sexual pervert and the criminally inclined, or that

feeble-mindedness is alternately the cause and consequence of alcoholism, immorality, pauperism, criminality, insanity, epilepsy, etc., but that *feeble-mindedness itself is hereditary*. Approximately 80% of mental defectiveness is transmitted from parent to child, and for reason of lack of self-restraint, the high-grade feeble-minded are almost twice as prolific as normal folk, as the normal family produces an average of about 4 to the feeble-minded family's average of 7 children.

#### *The Prevention of Feeble-Mindedness.*

In this connection, Von Wagenen, speaking of the great advance that has been made in the study of feeble-mindedness in the last ten years, says that the principal things to be sought are identification and control, with the object finally of elimination, and adds: "We know this: that restriction of marriage counts very little, because the feeble-minded don't care for marriage. Sterilization is not popular, for the general feeling is against it. States where laws have permitted it, have not practiced it to any great extent. So that we have to rely on segregation and education."

We need to know more about the effects of alcohol and syphilis. It seems now that alcohol and syphilis actually produce changes in the germ cells which tend towards mental deficiency. And there seems to be some relation between tuberculosis and feeble-mindedness. The plan for prevention should be along the lines of elimination of alcohol and all venereal diseases, and the prevention of the reproduction of the feeble-minded; because it is certain that a large percentage of feeble-mindedness (we do not know exactly how much) is hereditary.

In regard to segregation, Davenport says that it will eliminate feeble-mindedness practically in one generation. But it is evident that in making this statement he did not take into consideration the carrier of feeble-mindedness, i. e., a person one of whose parents or grandparents is feeble-minded, and who carries the defective germ plasm which united with a like cell will produce feeble-mindedness, although the carriers themselves may appear normal. However, segregation would be the means of ridding the community at large of much of its crime, pauperism, etc., and it is mainly through segregation and education that we will be able to check and stamp out the evil.

As to the educational side, the schools in some States are attempting to solve the problem by detecting the feeble-minded in childhood. The New Jersey laws require the local school boards to ascertain what children in the public schools are three years or more below the normal, and to establish backward classes for such children, of not less than ten nor more than fifteen children. The law also makes it obligatory upon the State Board of Education to prescribe a method of ascertaining what children are three years or more below normal. The method follows:

1. A study of the whole body of school children to ascertain the peculiarity of each class of children. (Under the law the formation of classes of mentally subnormal is compulsory, provided there are ten such children in any school district. \$500.00 is appropriated for each teacher.)

Plan of Investigation:

1. Tabulation by each teacher of all pupils on "grade and progress study cards."

2. Classification on the same card of retarded pupils.

3. A special study by a trained expert of those pupils who appear to be accidentally subnormal.

The retarded children are graded into three classes: (a) miscellaneous, (b) incorrigibles, (c) mentally subnormal. The grade and progress study cards also show the number of children above the average in ability. They are likewise being given special study. This classification is based on two theories of importance. First, *all* the children, and not merely some of them, should receive the benefits of education. Second, there are differences in the nature of children which must be taken into consideration in courses of study, and in the organization of schools.

To bring about the prevention of feeble-mindedness, we must first get the public to realize that there is a problem of the feeble-minded—this will go a long way toward the solution of the problem. Then, after we have detected the moron and the high-grade imbecile in the school, we must endeavor to segregate them in institutions on the colony plan, if possible, and until the colonies are large enough to hold the numbers ready, the excess should be reasonably and safely supervised and cared for in their homes, recognized for what they are; children in intelligence, though men and women in body.

#### *The Care and Maintenance of the Feeble-Minded.*

Dr. Fernald, at Waverly, Mass., speaking of his charges, says that the main idea is to keep them healthy, happy, and out of mischief, and to do this, work or recreation must be provided for every hour of the day, and that aside from the immediate disciplinary and educational value of the work, is the fact that the child is being fitted for a life of usefulness in the institution. The inmates seem to take well to the idea, for they assist in farm and garden work, help the baker, carpenter, and engineer, run errands between buildings, and keep the shoes of 1,300 inmates in repair. They also do the printing of the stationery, blanks, circulars, etc., for the school, and occupy themselves in many other serviceable ways. The girls work in the laundry, do most of the sewing, mending of the institution, and wash dishes, make beds, sweep, dust, and assist in the preparation of meals. And after the work period comes the play-time, when the children resort to well-equipped play grounds in the shady groves, and on rainy days assemble in their play rooms, or attend entertainments in the auditorium.

The motto at Waverly, Mass., "Everybody doing something," expresses the spirit of each institution visited. Even the crippled children at West-havershaw have their playthings, and are being educated as well as amused at the same time. And everywhere it seemed to be the consensus of opinion that mental defectives must not only be employed, but that back to the soil is the place for them. All new institutions are being located on large farms, and built on the colony plan, the patients being segregated in groups of fifteen to fifty. Farms of 250 to 2,000 or more acres have been purchased,

sometimes at a cost of only \$10.00 an acre, have been cleared and cultivated by feeble-minded people, under supervision, and much of this land is now worth \$100.00 an acre.

*The Economic Efficiency of the Feeble-Minded.*

Throughout the big institution at Waverly we saw evidences of the industry of the inmates. In the laundry we found 70 women at work, 60 of them being 3 to 10 years old mentally. Some of the inmates have become very proficient weavers; last year they wove 4,000 yards of mats and carpets. In the sewing department girls 6 to 10 years old mentally were busily plying their needles and running sewing machines. Last year they turned out 1,200 dresses, 6,000 shirts, and 2,000 stockings. They also spin, knit, and are dextrous at lace-making. Out on the farm we saw 40 low-grade inmates, 4 to 5 years mentally, clearing up land—digging up stumps and picking off stones; others 6 and 9 years mentally were working with them, doing the plowing and handling the heavier stumps. We learned that "boys" (inmates are usually called "boys" or "girls" no matter how old they are) of 4 or 5 years mental age were doing man's work after 4 years' training. Before receiving this training, which by the way, has cost no more than the ordinary expense of maintenance, they were absolutely worthless to society. It has been found, also, that it invariably requires more guards to handle the untrained than the trained patient, so in addition to an advance from zero to a fair degree of economic efficiency, there is a decrease in payroll for attendants.

In one of the institutions visited, a feeble-minded man cares for 800 chickens and does the work under supervision as well as a normal person could. Another looks after 17 cows winter and summer. He milks two of them and does all the stable work.

Speaking of the efficiency of the feeble-minded man, Mr. Alexander Johnson, of Vineland, N. J., says that he can be made to provide for himself by his work, and places his economic value at 55c. per day. The head matron at the Concord, N. H., Hospital for the Insane finds that the women patients average what is equal to half a normal person's efficiency. Some authorities, after placing the average economic value of a farm hand at \$1.50 a day, and figuring on this basis, have arrived at the conclusion that defectives, excepting idiots, vary in economic value from 30c. to 75c. a day, the general average being 54.6c., which is more than the cost of care and maintenance.

Here on Virginia soil we have a few examples of what the feeble-minded of the high-grade imbecile and moron class can do. At the State penitentiary 15 out of 22 third-conviction men and 88 women out of 96, were found to be high-grade imbeciles or morons. Now, as the State receives for the labor of these persons 85c. a day for the men, and 50c. a day for the women, and every year the penitentiary shows a profit, manifestly they earn more than their support. They would earn as much in a colony. At the State Farm, out of 78 men examined, 34 were found to be feeble-minded. They also are earning their support and could be made to do as well in a colony.



At the Virginia Colony for the Feeble-Minded, with a rated capacity of only 50, the institution is caring for 63 women. Many of them assist in the routine work of cleaning, sewing, mending, washing, and help in the preparation of meals. As an example of what is being done, we cite the case of the wife of James Z. (see page 53 and frontispiece). This woman is the mother of four feeble-minded children, and had, together with her husband and growing family, been living on charity for ten years or more, before being taken in charge and committed to the colony. She was constantly a menace to the community in which she lived. Now, after a six months' stay in the colony, she is doing well there—is assistant nurse, happy and contented in her work, and is spoken of in terms of praise by the superintendent. She and several other women of her stamp are more than earning their support instead of being burdens and menaces to public welfare. However, the institution is not suitably equipped (through lack of funds) to train the general run of feeble-minded to become more efficient economically; and furthermore, its present population represents only the worst cases of feeble-minded women of child-bearing age, and could not be regarded as typical of the population of an institution such as they have in Massachusetts or New Jersey, for instance. But with its present capacity and equipment, it is doing work which augurs well for the future.

*Summary.*

We have seen that the civilized nations of the earth are awakened to the menace of feeble-mindedness, and are taking steps for the elimination and prevention of this evil; that the worst phase of the matter is that approximately 80% of mental defectiveness is transmitted from parent to child, and for reason of lack of self-restraint, the high-grade feeble-minded are producing 7 children to the normal family's average of 4 children; that the principal things to be sought are *identification* and *control*, with the object finally of elimination; and so we will have to rely largely on segregation and education for the prevention of feeble-mindedness.

We have seen as a result of the study of the methods in use for the care and maintenance of the feeble-minded, that the main idea is to keep them healthy, happy, and out of mischief, and to do this, suitable work or recreation must be provided constantly; and that we must take our mental defectives back to the soil to get the best results.

We have seen as the result of the study of the economic efficiency of mental defectives, both in Northern institutions, and in institutions on Virginia soil, that the feeble-minded can, under *proper supervision*, be made *self-supporting*, excepting idiots.

## Chapter III.

### The Relations of Heredity to Feeble-mindedness.

*As Shown by a Study of a Virginia Family of Defectives.*

It is generally accepted that bad heredity is the cause of fully two-thirds of the cases of feeble-mindedness. For instance, Dr. Walter E. Fernald states that sixty to eighty per cent. are of direct inheritance, and Dr. H. H. Goddard has found that one or both parents of sixty-five per cent. of the children in the Vineland institution are actually feeble-minded, and registers his conviction that eighty per cent. of feeble-mindedness is hereditary.

However, it is not the purpose of this study to show similar averages; neither is it an attempt to discuss whether or not the laws of Mendel apply in the inheritance of feeble-mindedness; but its purpose is to show what has been found here in Virginia; to demonstrate by an analysis of a Virginia family that where both parents are mentally defective, feeble-mindedness is inherited not only by one child, but by all the children in the family; to bring home to us by examples within our gates that the predominating cause of feeble-mindedness is found in bad heredity, and that only by striking at the fountain-head can we hope to dry up the springs of this evil.

This paper is an attempt to give briefly an estimate of the mental condition of the X family through several generations, together with other information concerning them which could be obtained in the limited time assigned to this division of the investigation. Except in case of deceased members, no second hand evidence of an individual's mentality was accepted, and even this was in every instance corroborated by the testimony of more than one person who had known the subject in his lifetime. The informants were, of necessity, persons of undoubted mentality and of standing in the community, many of them former employers of the subjects of the inquiry.

Of 468 members of the X family charted, we have evidence concerning 311 members. Of these, all the living members were personally interviewed by the investigator. As a result of this investigation, 310 out of a possible 311 members of this family are believed to be feeble-minded.

#### *In the Home of the X's.*

There are representatives of this family in our orphanages and placing-out agencies, in the hospitals for the insane, in the reformatories, in the Colony for the Feeble-minded, in the penitentiary, and at the State Farm—in short, you will find them in every institution for degenerates in the State. For generations their name has been a by-word in the communities which they have infested. It implies shiftlessness, indolence, general inability, miscellaneous worthlessness, immorality, vice, and irresponsibility. Of them a well-to-do farmer said, "Yes, I know Old Sal and all her tribe. Why, they have been living on us for years. What they want that we don't

give them, they steal. Sometimes we can get the men to help us in harvest time, but they are uncertain and pretty worthless labor at best. You have to tell them what to do and then watch them do it."

A trip to their homes is sufficient to convince even the most skeptical that they are "uncertain and pretty worthless," and furthermore that they are mentally deficient to a notable degree. To know them one must visit them in their homes, as the investigator did.

In a ram-shackle hovel about twelve feet square, situated at the forks of two mountain roads, and overlooking a precipitous slope, lives Old Sal, the mother of nine feeble-minded sons and daughters, who in turn have propagated their kind until the number of Sal's living descendants aggregates forty-seven—and apparently not a person of normal mentality among them.

In this hut were found eight persons sitting on a bed covered with filthy rags, and huddled about the rickety cook stove in makeshift seats. One might have taken them for statues—they were so still. They were not working; they were not talking; one felt that they were not even thinking. When questioned they answered in monosyllables, and enumerated their family connections and respective habitations only after lengthy cross-examination. In a half hour of conversation, so one-sided that the word seems a misnomer, not a single spontaneous remark was offered by any of the group. And yet one felt that their attitude was not caused by antipathy, but was rather the result of the indifference, the apathy, the mental lethargy of the typically feeble-minded.

There were in the room Mary Jane, a slatternly-looking woman of forty-five (an illegitimate daughter of Old Sal), the mother of five illegitimate children, all girls; two of Mary Jane's daughters, age 20 and 14, respectively—already they had entered a life of prostitution—the girl of 20 has borne four illegitimate children, the youngest, two weeks old, being the only living one; another granddaughter of Old Sal who claims to be married to a man in the neighborhood (said to be feeble-minded), and the children of this woman, two girls and a boy, who already bore the stigmata of feeble-mindedness inherited from their defective parents.

Up the mountain side a few hundred yards, in a hut even smaller and more wretched than Old Sal's, lives Phyllis, another illegitimate daughter of Old Sal. A physician who has visited her vouches for the existence of trachoma, syphilis and hookworm, and in addition, she is a low-grade imbecile and very deaf. Yet despite her many infirmities, she has been allowed to bring into the world three feeble-minded daughters.

On the other side of the ravine, a little further up the mountain, is a house slightly more pretentious than the others. There are two rooms, one above and one below, a small lean-to, and a rickety porch. On the ground were several bushels of decaying apples which appeared to have been there for a number of days. The cabin, although roomier than the others, is also dirtier, which is no surprise when one learns that nine persons occupy its limited space.

There lives the most vicious and immoral family in a community where virtue is not regarded as an asset. This family, which is closely related to the X's, consists of Peter Z, his second wife, Catherine, and seven of their

thirteen children. They are without exception feeble-minded. Peter is about 45 years old, of medium height and weight. Small pale-blue eyes, the pupils of which are contracted to tiny dots, seem to stare unseeingly, uncomprehendingly at one; and protuberant ears covered along the outer edge with long bristly hair, these with certain facial lines make one feel that he is not far removed from the brute, and is perhaps cruel with the unconscious cruelty of an animal. When questioned, he answered as across a misty barrier, and appeared to be laboring always in a mental fog, impressing one at times as being unable to see, and at others as being unable to understand.

From the family and reputable citizens of the community one learns a story that seems well-nigh unbelievable. Peter's first wife, Susan B was a feeble-minded member of a family notoriously weak mentally and morally. Of this marriage five children were born, all feeble-minded. One of the girls, Samantha, had a child by an incestuous union with Peter. The child is reported to have been burned alive. Peter is alleged to have said that there were too many children around the house, and so the surplus was thus eliminated. However, Samantha rebelled and ran away from her unnatural father. Peter went after her, and with a doll as bait, enticed her to return home. Samantha, although a grown young woman, had never owned a doll, and for a season she was happy in her new possession and amenable to Peter's discipline. But as time went on she became unmanageable once more and Peter beat her soundly. A good woman of a nearby town, telling of an errand of mercy to this little home, said: "Peter used to stand in the middle of the room with a whip in his hand and make the woman do as he pleased." On this occasion though, the law stepped in, asserted itself, and Peter served six months on the roads.

Susan died of cancer sometime ago. She was a weak creature and evidently very low-grade mentally. In speaking of her family she would often say with an air of pride, "You know, my sister Catherine is pretty and Peter has just as many children by her as he does by me." Confirming this, it is said that Catherine had three children by Peter before Susan's death. As would be expected, they are feeble-minded, and the experience of Samantha has probably been duplicated in the lives of the two eldest girls except that they either lacked her scruples or courage to rebel. If any children were born to these girls they have not been heard of.

Since Susan's death, Catherine and Peter have considered themselves married, although no ceremony has been performed. Three more feeble-minded children have been born to them, two boys and a girl. Besides these there were two other children born to Catherine as a result of illicit intercourse with other men. And so the family is still growing. Something ought to be done about it? Well, an attempt has been made. At the time Peter was sent to the roads for beating Samantha, the children were placed in institutions and for a time the family seemed to be broken up. But not for long. Placing the children in suitable institutions and leaving their parents free to breed at will, would keep the rate of taxation on the increase forever providing the necessary institutions. No; such measures are palliative. Only by striking at the fountain-head, i. e., by sterilizing



or segregating all feeble-minded child-producers, can we hope to dry up the springs of feeble-mindedness.

*Summary.*

This investigation reveals the following facts:

1. In 35 cases where both parents were feeble-minded, 100% of the 140 children seen were feeble-minded. Twelve of these couples had six or more children.

2. In ten cases where both parents were feeble-minded, where only a part of the offspring could be seen, 100% of the children examined were defective. Here there were 33 feeble-minded children and 18 uninvestigated.

3. In 12 cases where one parent was feeble-minded, 100% of the children seen were found to be feeble-minded. There were here 32 feeble-minded cases and 14 uninvestigated. This would seem to indicate that several of the uninvestigated might also be feeble-minded.

4. In one case where the mentality of both parents could not be ascertained, there were 14 feeble-minded children and one undertermined child. Here we would suspect defect in the parents.

Here is the history of a family perhaps unique, but not essentially different from dozens of other families in this State. One sees how unerringly the results of such unions can be calculated, how rapidly the number of defectives increase, and this is not peculiar to any one section of the State, nor to any one of the United States. It has been estimated that in every State of the Union, so rapidly do they multiply, from 3 to 4% of the population are mentally defective. New Jersey has found that the number of defectives within its borders has doubled in one generation. The Department of Public Health and Charities of Philadelphia stated in 1910 that Philadelphia had at that time 3,000 evident cases of feeble-minded persons, and 8,000 others so deficient that they would be recognized by a trained examiner. The second class, no doubt, includes morons, the most difficult to detect and the most dangerous to the community. Dr. Davenport in a recent paper discusses the frequency of this class and the necessity of recognizing their menace to society. He says:

"A new plague that rendered 4% of our population, chiefly at the most productive age, not only incompetent but a burden costing one hundred dollars each yearly to support, would instantly attract universal attention and millions of dollars would be forthcoming for its study as they have been for the study of cancer. But we have become so used to crime, disease and degeneracy that we take them as necessary evils. That they were in the world's ignorance, is granted; but that they must remain so, is denied."

However, we are at present concerned only with Virginia, although we recognize that other States have the same evil to combat, and wish them well in their fighting. The various charts appended to the studies that go to make up our State-wide report, represent the degenerates found

in Virginia cities, towns, villages, and rural communities, in the mountains, the valleys, and by the sea—from every quarter of the State. Who reads will see that mental degeneracy is responsible in large degree for pauperism, crime, prostitution, and other evils which burden society; and reading will think, and thinking will vision what the future of our State will be if we do not sterilize or segregate all feeble-minded child-producers, and thus by striking at the fountain-head dry up the springs of feeble-mindedness.

# Chapter IV.

---

## The Relation of Feeble-mindedness to Insanity.

*As Shown by a Study of Two Hospitals for the Insane and an Inquiry into the Family History of Patients.*

The old idea that "It takes a smart man to become insane" has been given up as fallacious, for now we know that the amount of a person's intelligence has nothing to do with it. Unlike feeble-mindedness, which is a condition of arrested development due in large proportion to heredity, insanity is a manifestation of a diseased condition of the brain. And it was with the idea of ascertaining whether or not insanity and feeble-mindedness come from the same kind of neuropathic families, or in other words, the relation of insanity to feeble-mindedness, that this division of the investigation was made.

In this paper we have attempted to establish the relation between insanity and feeble-mindedness by

1. A study of mental deficiency in two hospitals for the insane, and
2. An inquiry into the family history of patients.

It was through the courtesy and aid of Dr. W. F. Drewry, superintendent of the Central State Hospital, and of Dr. J. C. King, superintendent of the Southwestern State Hospital, that the first part of this investigation was prosecuted, and the second part is based on field work.

### *In the Hospitals for the Insane.*

In the Central State Hospital (for the colored insane), 248 patients were interviewed, but as 51 proved too demented or disturbed to examine with accuracy, the actual number tested with the Binet scale was only 197. This number is not truly representative of the population as a whole, but is composed of four selected groups as follows:

1. New cases, or those patients who had entered the hospital during the four months preceding the examination. Every patient rational enough to answer questions was examined.
2. Cases selected as feeble-minded by the hospital officials.
3. The criminal insane.
4. Cases being sent out on parole.

Reactions were obtained as follows:

GROUP	NEGRO NUMBER TESTED		NEGRO PER CENT. FEEBLE-MINDED	
	Men	Women	Men	Women
New cases.....	68	46	82.3%	89.1%
Selected cases.....	17	22	100. %	95.4%
Criminal cases.....	40	8	92.5%	87.5%
Paroled cases.....	8	8	50. %	87.5%
Total.....	133	84		

This will not agree with total as several are classified under two heads

*The Correlation Between Chronological and Mental Ages.*

Chronological Age—Mental Age	3	4	5	6	7	8	9	10	11	Normal	Total
Under 21.....	2	1	1	2	6	10	2	1	1	2	28
21-30.....	1	1	8	7	12	18	12	4	1	5	69
31-40.....			2	4	14	13	13	4		9	59
41-50.....		1			4	7	4		2	4	22
51-60.....				2	6	1	1	1		2	13
61-70.....					2	2	2				6
Total.....	3	3	11	15	44	51	34	10	4	22	197

88.8% feeble-minded.

Negro men.....87.5%

Negro women.....90.9% feeble-minded

In the Southwestern State Hospital (for white insane) only three groups of patients were examined, i. e., new cases, selected cases and criminal cases. The total number interviewed was 125, of which 60 were too demented, disturbed or sick, to be tested.

Reactions in 65 cases were obtained as follows:

GROUP	WHITE NUMBER TESTED		WHITE PER CENT. FEEBLE-MINDED	
	Men	Women	Men	Women
New cases.....	28	10	46.4%	90. %
Selected cases.....	2	1	100. %	100. %
Criminal cases.....	26	2	69.3%	100. %
Total.....	56	13		

N. B.—Several classified under two heads.

*The Correlation Between Chronological and Mental Ages.*

Chronological Age—Mental Age	5	6	7	8	9	10	11	Normal	Total
Under 21.....					4			1	5
21-30.....	1	1	1	5	3	2		8	21
31-40.....		1		2	2	3	2	6	16
41-50.....				2	1	3	2	5	13
51-60.....			1	1	1	1		3	7
61-70.....				1		1		1	3
Total.....	1	2	2	11	11	10	4	24	65

63.1% feeble-minded.

White men.....58.9% feeble-minded.

White women.....92.4% feeble-minded

*New Cases.*—It will be noted that negro men tested 82.3% and negro women 89.1% feeble-minded, against 46.4% of defect in cases of white men and 90% in cases of white women. The reactions of this group give a fair idea of the mentality of patients as they enter the hospitals, and it is, therefore, the most indicative of the series. The total percentage of defect is 78.2%.

*Selected Cases.*—These cases, as they had already been diagnosed by the physicians in charge as feeble-minded, require no comment save that the reactions of the psychological test but confirmed the hospital diagnoses. The inclusion of these cases in the general tables raises the percentage of feeble-mindedness above a level of what might be indicative of the population as a whole.

*Criminal Cases.*—Here the negro men show 92.5% and the negro women 87.5% of defect against a percentage of feeble-mindedness in cases of white men of 92.5% and white women of 87.5%. The inclusion of this group in the general tables, as has been said of selected cases, raises the proportion of mental inferiority of the total number tested. The total percentage of feeble-mindedness in criminal cases is 84.2%.

Comparing the percentages of defects as shown by the two races, it will be noted that 88.8% of negroes registered as feeble-minded, and that the whites reacted 63.1% feeble-minded. There appears to be only a slight difference between the mental level of the negro males and females, but it will be observed that among the whites, males tested 58.9% feeble-minded, and the females 92.4%. This, however, may be accounted for when the disparity in numbers is noted, and the fact taken into consideration that as a rule the tendency is to care for cases of insanity among white women as long as possible in the home, and that it is only the extreme or difficult cases which are sent to the hospital.

Assuming that the 114 new cases among the negroes and the 38 new cases among the whites are representative of the hospital population as a whole, the percentages of feeble-mindedness would be as follows:

The white insane .....	57.9% feeble-minded.
The negro insane .....	85.1% feeble-minded.

Granting this to be true, then by eliminating the feeble-minded, we would reduce our insane population in these proportions. Certainly the results of the test indicate that if we reduce feeble-mindedness we will in proportion reduce insanity.

#### *The Family History of Patients.*

*Chart 67.*—G. J., one of the criminal insane inmates of a State Hospital, is the son of pauper parents, his mother and father now being inmates of an almshouse where they have resided for some years. G. J.'s sister, whose mental condition could not be determined, is known to be paralyzed and in a home for cripples, and he has a brother in a home for feeble-minded boys. One sister is married and has moved away. Her mentality is undetermined.



G. J. spent his early years in an orphanage and, later, through running afoul of the law, he spent a few years in a reformatory for boys. After being liberated, he is said to have fallen in with loose women who used him as a servant. He wound up his career by assaulting a woman, when for this he was committed to the criminal ward of the State hospital.

G. J. is undoubtedly of neuropathic stock which has culminated in insanity and feeble-mindedness. He is criminal (manic depressive) and a high-grade mental defective. He is one of five defectives out of a family of six—five-sixths of his known relatives in institutions.

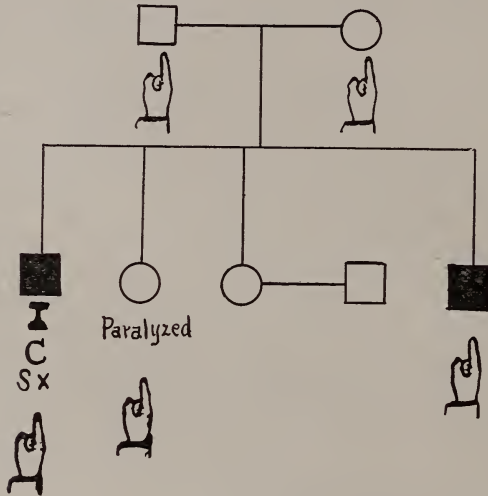

CHART 67.

Chart 64.—In the first generation the central mating is between an alcoholic man and woman whose family history is unknown except that she had a brother who received outdoor relief for many years. The man's two sisters were insane and in a State hospital. This central mating resulted in five children, the mental condition of four of whom is undetermined. One of the four married and as a result of this union has three children, one of whom is reported as normal, one feeble-minded and one a border-line case. The fourth person in the second generation is both feeble-minded and alcoholic and is married to a feeble-minded woman who has been in the State hospital for the insane. They have twelve children, the mental condition of one being undetermined, and of the remaining eleven, three died in infancy and eight are definitely feeble-minded. We have in this family three persons who were in hospitals for the insane, seven border-line cases, one "peculiar," and fourteen feeble-minded.



Chart 63.—The insane woman on this chart has been a pauper also, and was at one time in the same almshouse that sheltered the rest of her family. All are feeble-minded, the six children and the father. Of the mother we

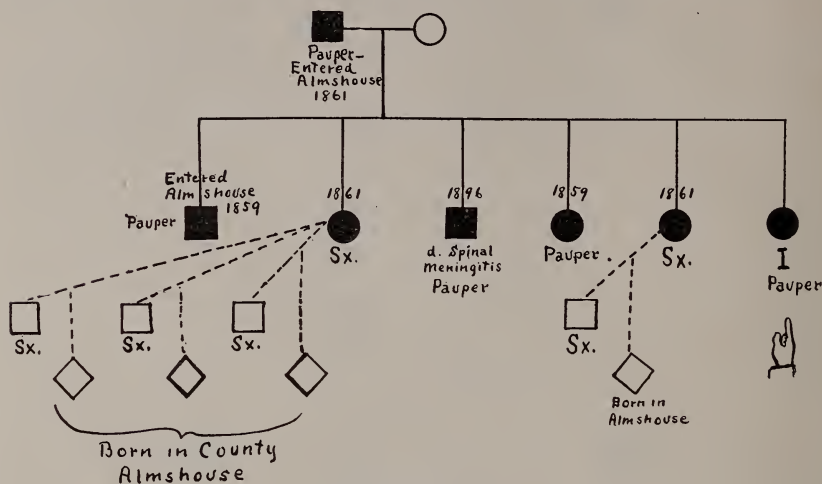

CHART 63.

know nothing except that she disappeared a good many years ago. Two of the sisters have been immoral, one having given birth to one illegitimate child, and the other to three. All of these children were born in a county almshouse.

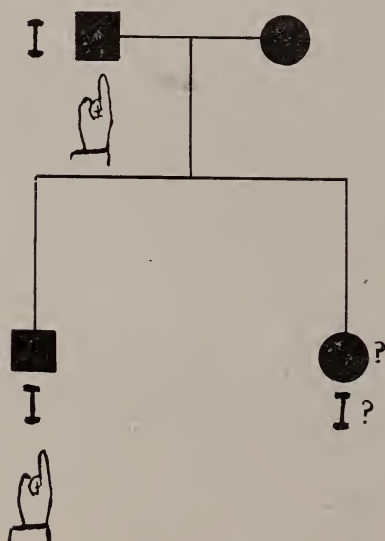

Chart 73.—Here is feeble-mindedness and insanity co-existent in a family in two generations. The patient in the second generation was an inmate of a State hospital, being both mentally inferior and insane. His father and mother were both feeble-minded, and the father was an inmate of another institution in the State. His sister was also insane and feeble-minded.

CHART 73.



Chart 52.—This chart shows insanity in the first generation (the person in question having been an inmate of a State hospital), and feeble-mindedness in the second and third generations. This family was for thirty years supported by the church of their community.

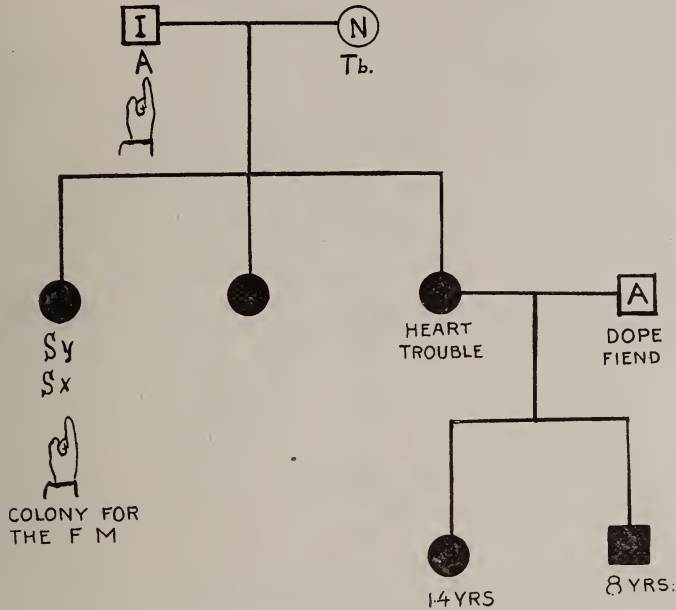

CHART 52.

Chart 53.—The central mating is between an insane woman who is an inmate of a State Hospital and an alcoholic man, both of alcoholic stock. Two of their children died in infancy, one is normal, six undetermined (one of whom, however, is in an institution), and three feeble-minded. This is an example of insanity and feeble-mindedness springing from the same general source. (See page 28.)

In addition to the foregoing cases fourteen others were studied, which in the main show the same results, *i. e.*, that feeble-mindedness and insanity appear not only in the same individual but in the same families, sometimes for several generations.

Summary.

From a study of mental deficiency in two State hospitals for the insane, taking as typical of the whole population the new cases, or those patients who had entered the hospital during the four months preceding the examination, we find that 57.9% of the white and 85.1% of the negro insane appear feeble-minded; and that furthermore, an inquiry into the family history of twenty cases confirms the reactions of the psychological examination, and

demonstrates that not only do feeble-mindedness and insanity occur in the same individual, but also in the same fraternities, and appear to arise from the same neuropathic make-up.

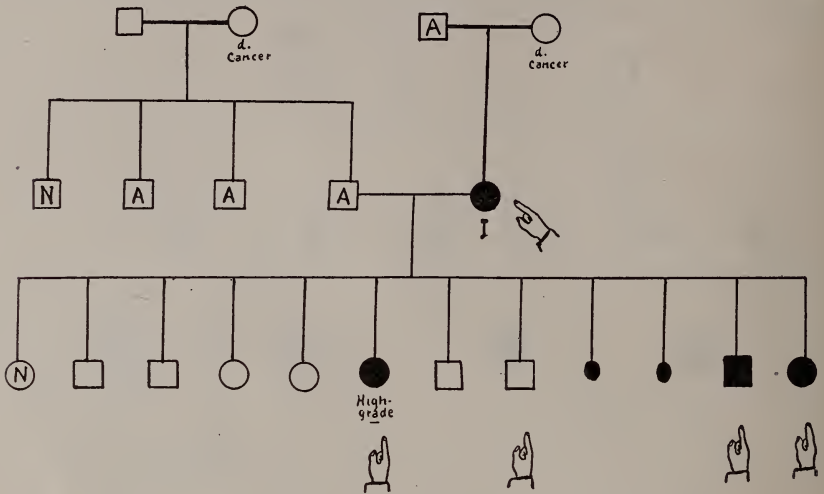

CHART 53.

## Chapter V.

---

### The Relation of Feeble-mindedness to Epilepsy.

The growing prevalence of epilepsy and the awakened necessity of caring for epileptics led to the establishment in 1910 of a colony in Virginia to provide for this class of defectives. That they are usually helpless and incapable of defending themselves from the dangers attendant on normal life is well known; that they usually transmit to their offspring a taint which may produce epilepsy, feeble-mindedness, insanity, or similar disorder of the central nervous system as to induce the adoption of means of prevention, has not been so generally recognized; but there are now nine States in which laws have been framed to prohibit the marriage of epileptics. In Connecticut, Indiana, Kansas, Minnesota, Michigan, New Jersey, Ohio, Utah, and Washington, the epileptic is recognized as a menace to the growth of a healthy community, and these States are seeking to cut off the supply of this expensive class of defectives—for it costs more to maintain the individual epileptic than the individual of any other class of defectives; because he oftentimes has a distinct criminal tendency, he needs special medical care, he frequently becomes insane, and for a long term of years before the disease has reached its climax, he is liable to marry and produce his kind.

It is impossible as yet to state definitely the principles governing the relation of epilepsy and feeble-mindedness, for it is a matter which has not yet been cleared up. That one neuropathic strain when united with a like strain will produce epilepsy, feeble-mindedness, and insanity, and when united with a stronger strain will be manifested in hysteria, neurasthenia and the like, has been accepted for some time. Further progress is to be made chiefly by the study of family histories. Church and Peterson in "Nervous and Mental Diseases," say:

"In determining the factor of heredity, we must not be content with ascertaining the existence of psychoses in the ascendants, but we must seek, by careful interrogation of various members of the family for some of the hereditary equivalents, such as epilepsy, chorea, hysteria, neurasthenia, somnambulism, migraine, organic diseases of the central nervous system, criminal tendencies, eccentricities of character, drunkenness, etc., for these equivalents are interchangeable from one generation to another, and are simply evidences of instability of the nervous organization that is inherited, not a particular neurosis or psychosis, and it must be our aim in the investigation of the progenitors to discover the evidence of this."

That these indications of neuropathic ancestry are inextricably interwoven is evident to students of mental degeneracy, but to thread the maze

and determine the exact degree of relationship is an almost insurmountable task. So this study is only an attempt to show that these two—epilepsy and feeble-mindedness, go hand in hand, and not in what proportion one exceeds or is caused by the other; that they are co-existent; that they occur not only in the same fraternity, but oftentimes in the same individual; and that the extermination of feeble-mindedness will eliminate a large proportion of epilepsy, and do away with much tainted germ plasm which is destined to produce more degeneracy.

This problem has been approached along two lines of research: (1) by attempting to determine the mentality of a given group of epileptics, and (2) by studying the family histories of several cases with a view to ascertaining what proportion of a known epileptic fraternity was epileptic and what proportion feeble-minded.

The first part of this investigation was prosecuted at the Virginia Epileptic Colony, through the courtesy of the superintendent, Dr. A. S. Priddy.

The colony is of such recent origin that the patients comprise principally cases transferred from the hospitals for the insane and the county institutions, which until this time had been harboring them. Therefore, due to the deterioration of mental processes that usually accompany epilepsy, the mental measure of the patients is found to be lower than it would be in a group of epileptics selected at random from the population at large, or from an older institution which includes a greater variety of cases.

*At the Virginia Epileptic Colony.*

Here a simple intelligence test was given to the 106 women comprising the population of the colony. This test consisted of asking the patient (1) her name; (2) her age; (3) the date; (4) her last place of residence; (5) the length of time she had been in the colony; and (6) to write her name. The result follows:

TEST	Succeed	Fall	Per Cent. Fall
Knows name .....	69	37	34.9%
Knows age .....	27	79	74.5%
Knows date .....	25	81	76.4%
Knows last residence .....	50	56	52.8%
Knows length of time in colony .....	37	69	65.1%
Writes name .....	33	73	68.8%

This test, while it is a good picture of the mental condition of inmates of the colony, is deemed insufficient evidence on which to base conclusions as to the epileptics at large in the State. The lack of knowledge of their previous residence and the length of time they had been in the colony, these are indicative, as none of them had been inmates very long—many but a few months. But to say that 34% of the 3,000 epileptics in the State do not know their names is, of course, absurd; to say that this group does not, is proof of their need of institutional care. It is also manifestly impossible to draw any conclusions as to the mental condition of these patients before their mental processes were affected, as their epilepsy was of

too long standing. It would be ridiculous to say of two equally affected that the one had been normal and the other feeble-minded. The only clue that we find to their previous mentality lies in their family histories, which as far as possible, have been investigated. A few of these are presented in the following charts:

*Chart 82.—Epilepsy and Feeble-mindedness in Three Generations.*—The central mating is between a sexually immoral woman who was alcoholic, a dope fiend, feeble-minded and epileptic, to a man of whom little is known save that he died of paralysis. They had three children, one of whom is feeble-minded, one unknown, and one who died at 23 of tuberculosis. The latter, a girl, was also epileptic. By a union with an alcoholic man she had an epileptic and feeble-minded daughter. The daughter, also an epileptic, married at 15 a man of undetermined mentality whose mother was feeble-minded. There are no children from this union. Here we have epilepsy by direct descent in three generations.

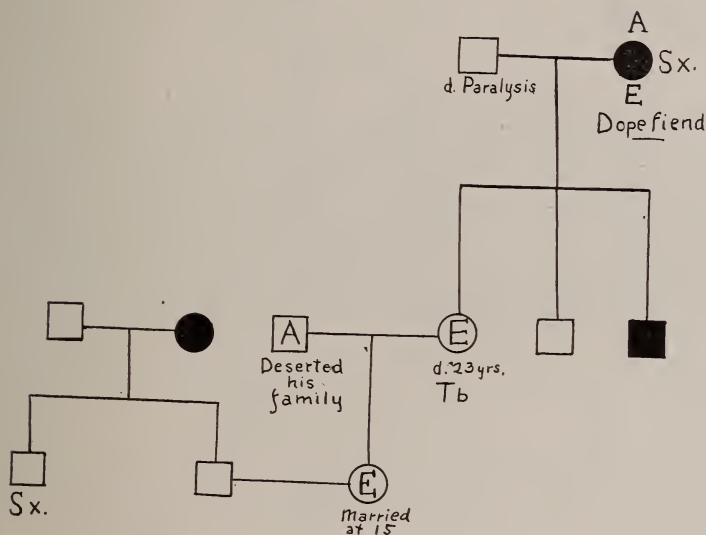

CHART 82.

*Chart 83.—The Family of an Epileptic Patient.*—The central mating is of an epileptic, insane, feeble-minded woman and a sexually immoral, alcoholic man. They had seventeen children, four of whom died in infancy, and six were registered as miscarriages. Of the remaining seven children, four are feeble-minded and three of undetermined mentality. One of the children, a low-grade imbecile, is in the feeble-minded ward of the colony; one married a feeble-minded man and had one miscarriage, one child who died in infancy, and one feeble-minded child. We find here epilepsy in the first generation and feeble-mindedness in the second and third generations.



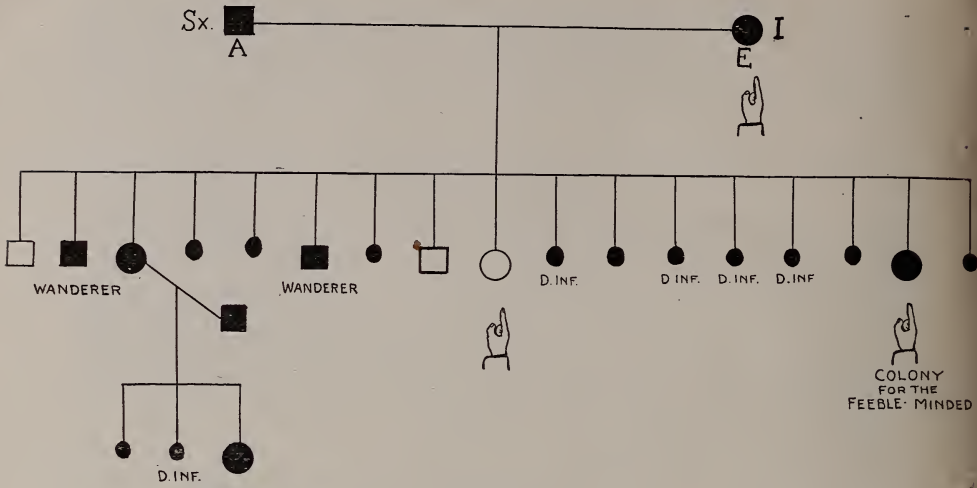

CHART 83.

Chart 84.—A Neuropathic family.—The central mating is of an insane immoral woman (a one-time resident of the segregated district) and an alcoholic man. They have had five children. The eldest died of “brain fever” at 13 months; the second is feeble-minded, the third is epileptic and a resident of the colony; the fourth and fifth are in an orphanage—they are very young. Note that two generations of alcoholism on the paternal side combined with insanity and neuropathic tendencies on the maternal side resulted in feeble-mindedness, epilepsy and “brain fever.”

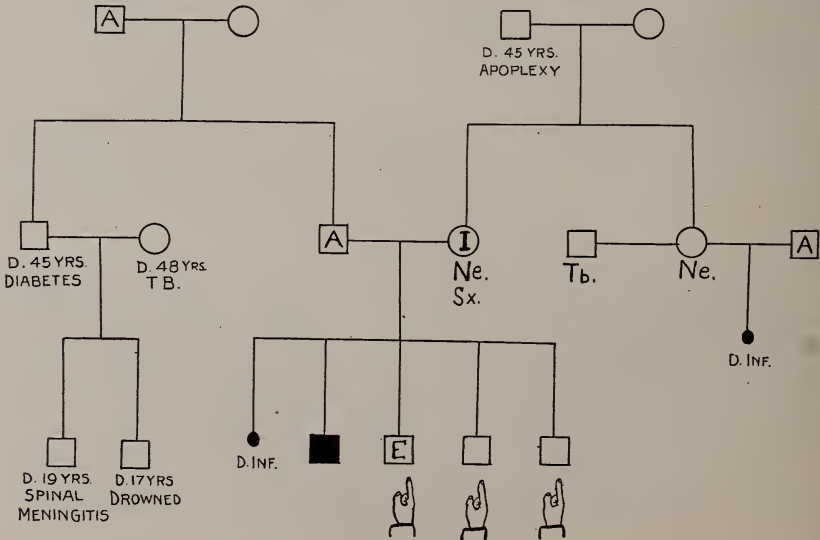

CHART 84.

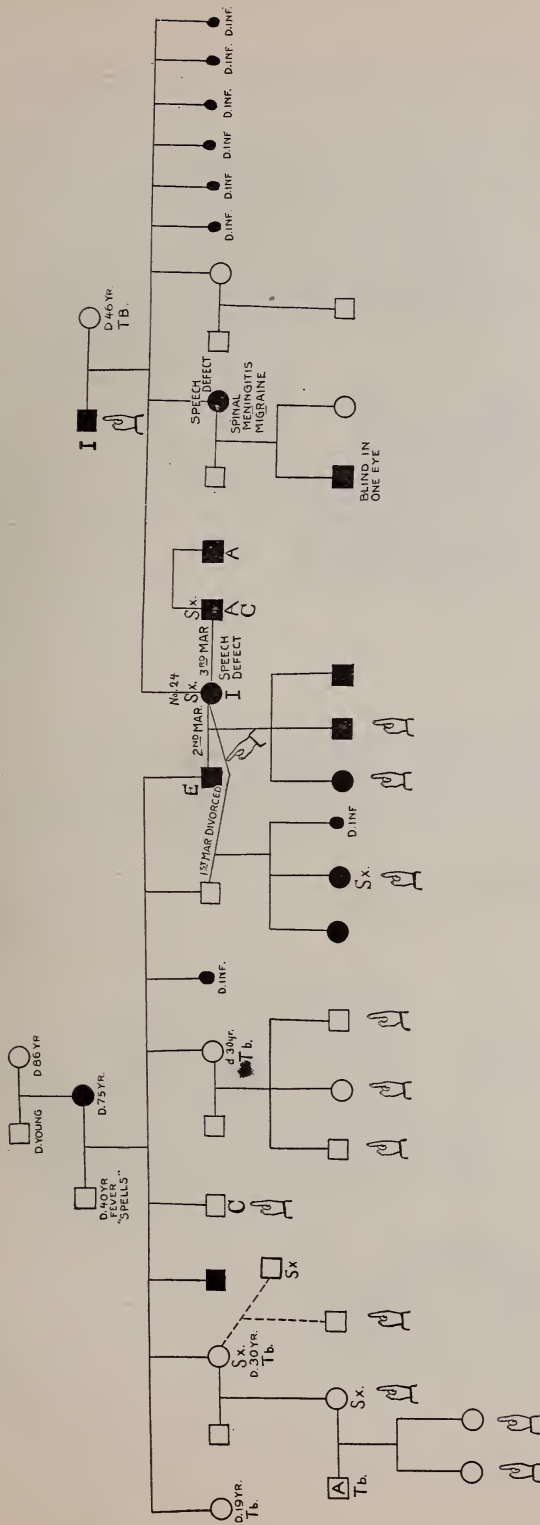

CHART 85.

*Chart 85.—An Institutional Family.*—Here the central meeting is of a feeble-minded, insane, immoral woman, No. 24, (thrice married) and a feeble-minded, epileptic man who died in the colony. This marriage which was the woman's second matrimonial venture, resulted in three feeble-minded children, two of whom are now in orphanages. Note that the woman's first and second husbands were brothers. By the first husband she had three children, one of whom died in infancy, and the other two are now living, one in a reform school and the other with a family said to be immoral. Both are feeble-minded. This woman, No. 24, was married the third time to a man with whom she had lived a while before her second husband was taken to the colony. Her third husband served a term in the penitentiary. He and his twin brother were feeble-minded. While the only epileptic member of this family died in the colony, it will be noted that the stock is unquestionably degenerate, summing up as follows: 13 feeble-minded (of whom one, an epileptic, died in the colony); 2 insane; 5 tubercular; 8 had marasmus; 8 died in infancy; a total of 14 in institutions. Orphanages, insane asylums, the Epileptic colony, the jail, and the penitentiary—all have known them to the cost of the taxpayer. This is an example of the rapidity with which defective germ plasm reproduces, with a prophecy of what the cost will be in future generations unless action is taken now.

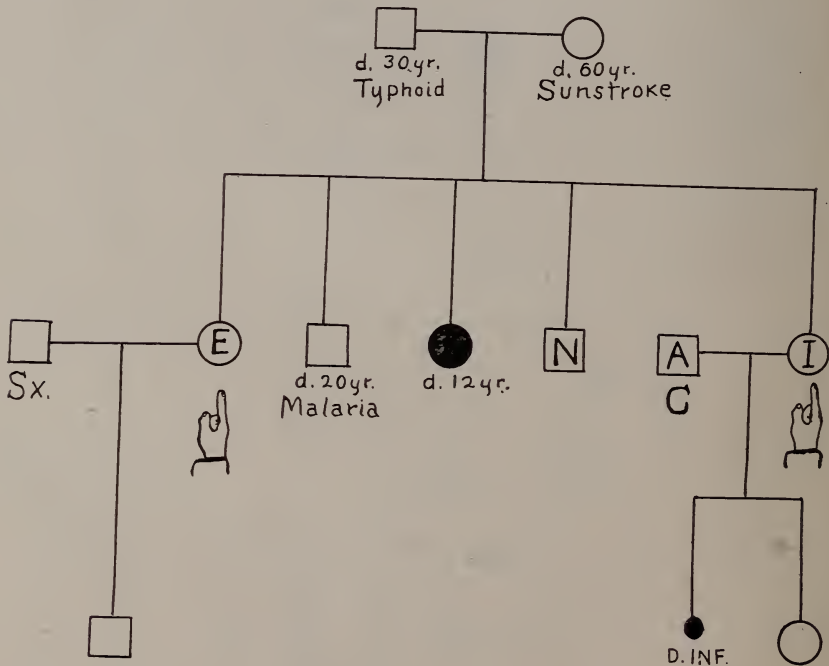

CHART 81.



SOME BUILDINGS AT THE VIRGINIA COLONY FOR FEEBLE-MINDED AND EPILEPTICS.





*Chart 81.—A Colored Family reported as "Queer."*—This family consisted of father, mother and five children. The father died at 30 of typhoid fever. The mother at 60 of a "stroke." As the parents have been dead for years it is impossible to ascertain their mentality. The first child, a daughter, is an epileptic. She graduated at the Negro High School and taught in the public schools for several years. Eventually, however, her seizures became so frequent that she was forced to give up her position, after which she taught a small private school for a while. Finally, she married a man who was very immoral and when he tried to exploit her she left him. They had one child, mentality unknown.

The second child died at 20 of malarial fever; the third was feeble-minded, and died at twelve; the fourth is apparently normal; the fifth was insane and attempted suicide; she was taken to the State Hospital and a cure was reported. After being discharged from the Hospital she let her child die of neglect. She now has a second child about three years old. Her husband is an alcoholic and has a jail record.

*Chart 90.—Feeble-mindedness in four generations; epilepsy in two generations.*—In the central mating the mother is a feeble-minded epileptic, a paralytic, and afflicted with tuberculosis; the father a feeble-minded man who was alcoholic, sexually immoral and syphilitic. Their two children are feeble-minded. The girl is in the colony in the feeble-minded division, and the boy has been cared for by a children's agency. He is a degenerate, morally as well as mentally, and although only fourteen, seems to be a confirmed thief. He has been placed in many homes, but has stayed in none. The stock on both the maternal and paternal side is characterized by a high incidence of feeble-mindedness with some epilepsy. Seventeen out of the 37 individuals on this chart have been seen and found to be feeble-minded. There are five epileptics, three of whom are feeble-minded. This is a good example of how feeble-mindedness and epilepsy appear in the same fraternity. (See page 36.)

#### *Summary.*

(1) The families presented in the foregoing, and others studied in connection with them, show that epilepsy and feeble-mindedness come from the same general defect of the germ plasm in the parents. (2) There is not sufficient evidence to enable us to make any definite conclusions as to the proportion of epilepsy in a feeble-minded family or the amount of feeble-mindedness arising from an epileptic fraternity. (3) But, there is sufficient evidence of the fact that were we able to segregate and prevent the procreation of the feeble-minded, this would be the means of eliminating a large proportion of epilepsy, and exterminate as well as much other defective germ plasm which is likewise destined to produce more defective germ plasm, and consequently more paupers, criminals, prostitutes, and other degenerates who would burden the taxpayer of future generations.

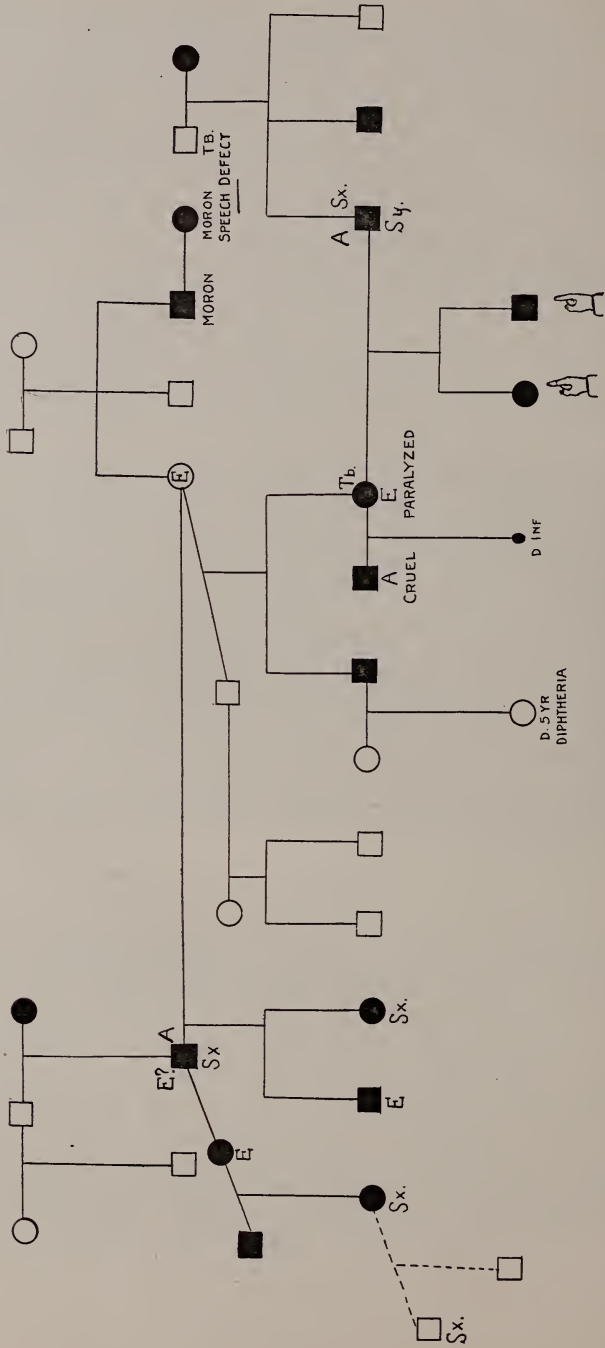

CHART 90.

## Chapter VI.

---

### The Relation of Feeble-mindedness to Pauperism as shown by a Study of Present Methods of Charity.

This paper reveals the following facts:

*That the people of Virginia spend at least two and one-half million dollars a year in attempting to aid the destitute.*

*That much of this money is being used to perpetuate poverty.*

*That our almshouses are virtually lying-in hospitals for feeble-minded women.*

*That certain feeble-minded families have lived and propagated their kind in almshouses for six and seven generations.*

*That many of our almshouses are populated by broken down criminals and worn out prostitutes, who come to these institutions to recuperate that they may be able to further indulge their passions.*

*That fully 80% of all persons in our almshouses are feeble-minded.*

*That certain pauper families have been supported by churches and organized charities for four and five generations.*

*That if these defectives were placed in suitable institutions before being wrecked physically, they would be made to earn their own support, and thus lighten the taxpayer's burden.*

This study represents six years of field work done in the course of routine inspection and one year of special investigation. In routine work every almshouse in the State was visited six times, and in the special investigation, thirty-three almshouses were given careful study with regard to the heredity, personal, economic, social, mental history of the inmates. This investigation was made by trained social workers who not only studied the almshouses and inmates, but also made a house to house canvass of the beneficiaries of outdoor relief in certain counties, and investigated the histories of pauper families known to be the recipients of both legal and volunteer outdoor relief. The information thus obtained was supplemented by reports from and interviews with pastors of churches and heads of organized charities.

This investigation was made for the purpose of ascertaining:

- (1) To what extent feeble-mindedness is responsible for pauperism;
- (2) The value of present methods of charity; and
- (3) Whether or not a better and more economical system of caring for defectives can be formulated.

Heretofore feeble-mindedness has not been stressed among the various assigned causes of poverty. The direct negative causes usually named, are tative causes, shiftlessness, indolence, ignorance, lack of training, improvident causes, shiftlessness, idolence, ignorance, lack of training, improvidence, intemperance, crime, vice, immorality, lack of responsibility, and family desertion. The indirect or environmental causes named are, lack of educational facilities, defective sanitation, poor housing, industrial condi-

tions, labor strikes, public calamities, insufficient remuneration for labor, congestion of population and immigration. But feeble-mindedness is the *primary cause* of a larger proportion of the foregoing assigned causes, and in many cases of poverty, the assigned cause is only a symptom of feeble-mindedness.

Churches and organized charities, almshouses and outdoor relief authorities in ignoring feeble-mindedness as a factor in pauperism, have failed to strike at the root of the matter. If feeble-mindedness is responsible for the greater part of pauperism, no method of dealing with the destitute can be effective that does not take this fact into consideration. If present methods of charity encourage the feeble-minded in anti-social habits and aid them to raise families which are and always will be a burden on the taxpayer, such methods should be abolished. The relation of feeble-mindedness to pauperism is, therefore, a vital matter and must not be ignored in any system of dealing with dependents.

#### *The Almshouse Population.*

It is commonly supposed that most of the occupants of almshouses have been at some time or other persons of respectable life and fairly prosperous circumstances, who through death, disease, or financial troubles, lost their means of livelihood. But such is not the case. The evidences herein presented clearly demonstrates that the almshouse is the last resort of incompetence and vice; that comparatively few of the inmates have ever owned property or kept clear of dependence; and reflects unfavorably on the system which forces respectable old and infirm persons to live with idiots and prostitutes. An analysis of the almshouse population of Virginia shows it to be divided into classes as follows:

1. Children born in the institution or who have proved so feeble-minded they cannot be placed in families, or children's institutions; or who are syphilitic or crippled.
2. Persons admitted in youth in consequence of their inability to earn a living.
3. Persons admitted later in life owing to the death of friends or relatives who had previously looked after them.
4. Prostitutes and vagrants—men and women who refuse to work, who find food and shelter in the almshouse in winter and tramp in the summer; and men and women who through dissipation are broken down and who come to the almshouse to recuperate.
5. Women who come to the almshouse to be confined and who will come again and again unless permanently segregated or otherwise given adequate protection against lecherous men.
6. Persons who find themselves friendless in old age. Poverty-stricken persons who are diseased.

#### *The Feeble-Minded in the Almshouse.*

On a visit of inspection to one of our almshouses, we stop at the door of a room. Before the door is opened a wild, uncanny sound is heard

from within. When you see the cause of the sound, and what a miserable, deformed creature she is, the sound seems consistent. She has never walked nor talked, and does not know one person from another; in fact, she has not even the glimmerings of intelligence manifested by some of the lower forms of animal life. She is the illegitimate child of a feeble-minded woman who came to the institution more than twenty years ago, gave birth to her child, and left it there while she went her way, perhaps to repeat the experience in some other community. And now the taxpayers are paying the price.

In the room with this woman is a blind imbecile who takes care of the illegitimate baby of a woman who was recently committed to the epileptic colony.

In the next room are several persons representing three generations of one family, Sam S., his mother, his wife, and four children. Evie S., Sam's mother, is physically strong. She is about fifty years old chronologically; mental age six. She has no idea of her age nor of anything involving numbers. So thoroughly does she lack this sense that she is not certain how many children she has had. Sam is the only one known to be living, and speaking of him, she says, "He was so sickly his Pa wouldn't bother with him 'cause he thought he'd die anyhow." The father is supposed to have killed by strangling or smothering the other babies. "He takes spells of going to live with other women," but, "she adds proudly, "he always comes back to me."

Sam is about 32 years old but nine years mentally. He is physically weak, but says he likes to work if some one that is kind to him will stay near and show him how. He went to school part of fourteen years, but cannot read and write. His wife is six years old mentally. At the time of her marriage she and her parents were inmates of the almshouse of a neighboring county. She then lacked one month of being fourteen years old, but in spite of her youth, had already given birth to one child, and another was born a few weeks after her marriage with Sam. Now at twenty-eight she has had fourteen children, seven of whom were born dead, and two died under two years of age. The oldest child has been taken into custody, but there is little hope of history not repeating itself—in fact, she is already following in her mother's footsteps. The next child is seven years old, and shows marked mental defect. The younger children, age five and three, have been placed with private families. The baby is with the mother, and will probably be in an institution the rest of his life, as he is deformed. This family has been to the almshouse several times to spend the winter, going out as warm weather approaches, but now they think they will stay permanently as they get along better there than anywhere else.

In another part of the almshouse we find an old woman, Mag, her idiot daughter, and Jim, the illegitimate child of another feeble-minded daughter. Three days ago these people were brought in half-starved, half-frozen, and in a pitiful condition. As we look in, we see the old woman rocking her body back and forth and striking the wall. Her hair is short, snow white, and bushy. It looks as though it has never felt a comb. In marked contrast Mag's is raven black and she is using a comb for the first time, de-



lighted as a child with a new toy. Jim hangs by his heels from the foot of the bed, and makes noises like a dog, which language he apparently knows better than human speech. These persons were brought to the almshouse because they were constantly begging for outdoor relief, which, however, failed to relieve, for the simple reason that they did not know how to prepare food when it was given them.

Here are Becky and her husband. They were inmates of an almshouse fifty miles away. He is paralyzed and claims that as his reason for seeking aid. Becky is an imbecile. They left the other almshouse to get married, and when they returned were refused admission. So they tried here and were admitted, and here they have lived ever since. Their oldest child is now thirteen, but only five mentally, and has symptoms of epilepsy. The other child has been adopted by a family living nearby.

Lize F. is well up in the fifties, and has spent half of her life in the almshouse, and doesn't regret it. She first came here to give birth to an illegitimate child. She later took her baby and went out to work. Two years later she returned to deliver the second illegitimate baby, and since then has remained in the institution. Her oldest child, a girl, is mentally defective, and is a prostitute. The second child had a negro father. She too was a prostitute until a few years ago, when she married.

Lize's brother and his family usually spend the winter in this almshouse also. His oldest child is sixteen chronologically, and seven mentally. She is a prostitute and is now serving her second jail sentence.

The superintendent's wife says: "Do not forget my best helper," and then we see Minnie. Fifteen years ago she came to the almshouse with her two children. She tells her story, "I could work out with one child, though it was hard to get a place on account of his being afflicted, but nobody would have me with two."

She has evidently tried to do right. This is proved by the fact that since coming here she has worked hard and made no trouble. Her son is now eighteen years of age but five mentally. He is epileptic. The other child fell into a kettle of boiling water and died when three years old. Both were illegitimate.

Minnie is a fine-looking woman, and would be called normal by the casual observer. She is a striking example of the type that is too weak to make good while out in the world, but does well under kindly supervision. She is six years old according to the reactions of the Binet test.

Besides these related groups we see an idiotic man, a woman, aged three mentally, another four years old mentally, two men testing six, a deaf mute female, one woman nearly blind, one stone deaf, and two others testing nine years.

All these people are white. In the colored wards we find one helpless cripple, two old, blind men, and an epileptic.

Lest the reader should think this an atypical almshouse and not a fair sample, we give a glimpse of conditions in the adjoining county.

Just as we step inside the institution an old woman opens the door and says "Come here, Boss, and see where the rats done played hog-eye with the only whole coat I got, and me a-savin' it to be buried in!" Truly the

rats had wrought ruin to the calico dress, which, according to the custom of the section, she calls a "coat." In one hand she holds a sleeve and a piece of the waist, and upon the bed is the rest. She resumes, "And this the only whole coat I ever had that was bought for me and not made like others; 'cause you see I been in the poorhouse all my life." "Were you born here, Betty?" is asked. "No, I was born down to \_\_\_\_\_ county poorhouse. My mammy and daddy lived there, and mammy's mammy and daddy too. We left in wartime. We were all poorhouse folks. I can't tell how many years I been here, but I can tell you many bosses we've had." Then follows a long history of her hard work, which characteristic of her kind she magnifies beyond the realm of probability. Later her family history was verified. In 1844 her parents entered the almshouse. During the civil war they got mad with the keeper's wife and tried to start an insurrection. When thwarted in this, they took their daughter and left, and soon entered the one in which the daughter now lives. Not only had her parents been inmates, but both grandparents and an uncle were also inmates, and all were recorded on the books as "simple."

All of Betty's children are illegitimate. Tom, the eldest, when grown decided to go out to work. He made very little as a farm hand and this he spent for whiskey and drugs. When a girl refused to marry him, he drank laudanum and laid down on the railroad track. This of course was the end of his career. The next child had a negro father. He was placed out in a home, and has been lost sight of. The only girl, Kate, works out for a while and then comes back for a stay. She is an imbecile. Already she has given birth to three illegitimate children. Her eldest has been placed in an institution in the North. Kate's next child was allowed to freeze to death in a blizzard. The third died of spinal meningitis. Kate is now at large, and will doubtless continue her career. This, the history of five generations of paupers, Betty gives without the least sense of shame, or any consciousness that her actions or family history have been out of the ordinary way of living. The idea of leaving the almshouse or trying to support herself without help has never dawned upon her.

Betty has for roommates an imbecile woman who is crippled, and a woman of eighty years or more who is suffering from senile dementia. There is another imbecile too sullen to talk much, but she speaks of two illegitimate children, fullgrown—"They won't take care of me, so I don't care where they are." Together these women care for the crippled child of a woman sent to the colony for the feeble-minded last year.

Coming to the men's department, we see first George, a representative of a notorious mountain family. George has a deformity of the joints, affecting his knees, ankles and elbows. He cannot walk, but pulls himself over the floor. He is of the sullen type of feeble-minded, and has a vicious appearance. He has more than once attacked the almshouse superintendent. He has a brother in a hospital for the insane.

Next we see a man of fifty whom any one would recognize as an idiot. "We just call him 'Boo.' When we came here they called him that and my predecessor said that all he knew about him was that one morning when he opened the door of the quarters there was a large basket. The lid was

removed and there lay a little baby saying 'Boo!' They unpacked the basket and found a supply of nice clothes and forty dollars in gold, but no clue as to where he came from."

Cy, the next man we see, is so deaf that conversation is well-nigh impossible. He is an imbecile and has suffered from what he calls the "trimbles" since he was a boy. He has been an inmate of the almshouse for forty years. His father and mother drew outdoor relief from their county for a number of years; his eldest sister is in the almshouse of the same county, and her illegitimate son died there after having been an inmate all his life; another sister, helpless from a stroke of paralysis has been there thirty years; and still another sister has a blind child that will soon be a charge on some community.

In the kitchen is Milly, a low grade feeble-minded girl who is also deaf and dumb. She is a cousin of Lummy and Eddie X., whose history is worthy of note. These persons lived in a small one-room cabin without windows or furniture. A little straw was the only bedding, and a few tin cans picked up on the mountain-side served as kitchen utensils and dishes. The father of this family died several years ago. His mentality was best testified to by Lummy, who said "Pap didn't know much. One time he picked two gallons of red-top clover and took it to town to sell for dew-berries."

They were noted as the wildest folk in the mountains, and when the report came that a baby had been burned alive by its mother, the county officers decided the bunch must be broken up. Two miles from the cabin the wagons had to be left, and the way made through the bushes. Upon the approach of the posse the two oldest sons ran away and hid in caves, but the old mother, Rildy and Eddie were brought to the almshouse. Later, Lummy was brought in from another part of the county.

She had gone to live with a cousin because there was nothing to eat at home. She is a lowgrade imbecile and very moody. Her two illegitimate children died in infancy and were buried at Joe X.'s.

"Joe is my brother-in-law," she says, "because he married my cousin, and was Pap's half-brother." This is the longest sentence she has been known to frame, and it speaks for itself.

Eddie did not know his name when he came to the almshouse. He stammers and never talks unless urged to. He is an incorrigible thief. Once he was found wearing three pairs of trousers which he had stolen from the other inmates. He has no idea of values. At one time he worked in the mines. He received one dollar a month wages and paid one dollar a month board, according to his account. He tells you that his sister has seventeen children, and after naming four, says, "That's all—ain't that seventeen?" In his face there is no sign of intelligence, and the same idiotic grin meets every remark made to him.

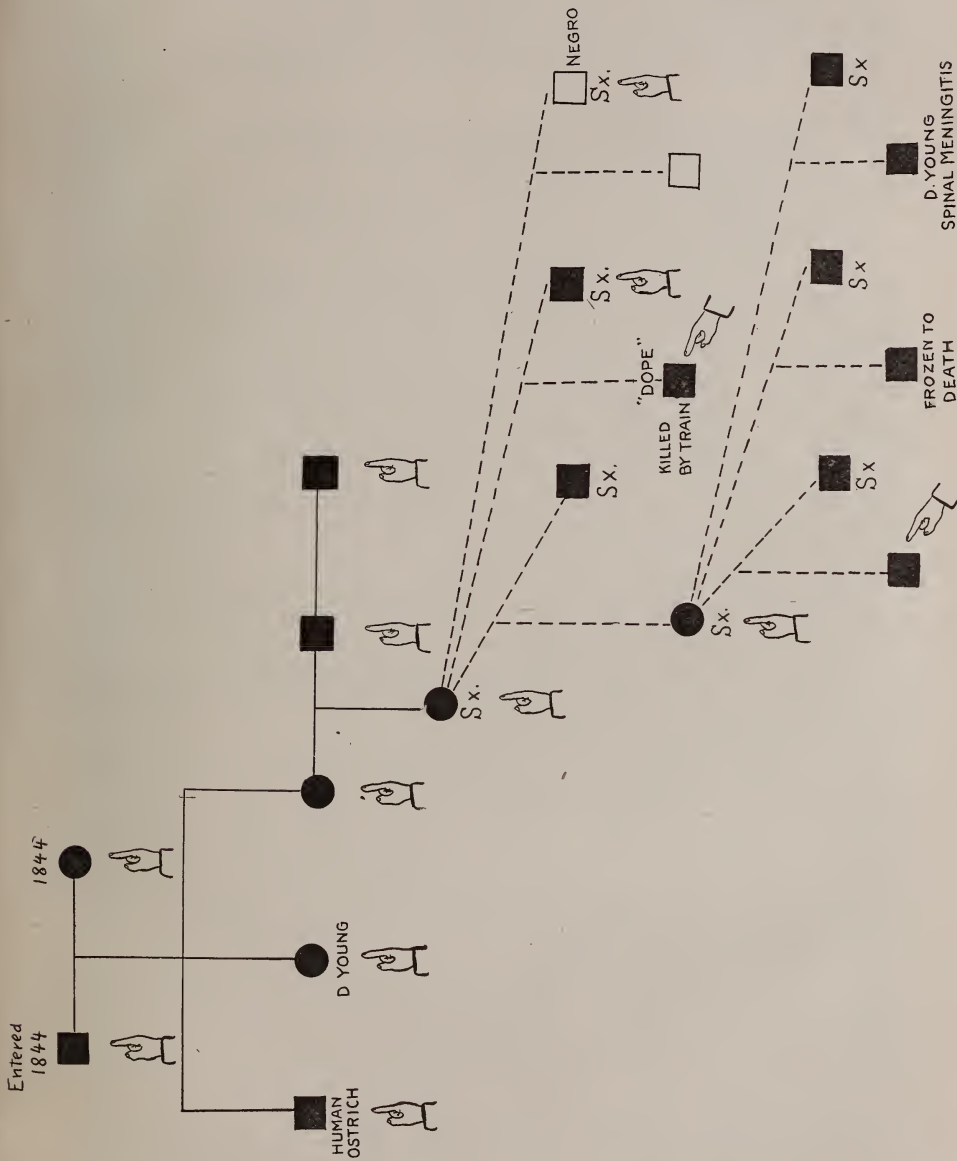

CHART 99. FIVE GENERATIONS IN ALMSHOUSES.



Rildy is now in the colony for the feeble-minded. She has had several illegitimate children, but her full history is not obtainable. One child died, and one she "put under the back-log and burned up."

The mother of this tribe died of over-eating soon after she reached the almshouse. Other members are at large, some are married and bringing up families, and others are bringing up families without being married. One of Rildy's brothers is dumb and has a child that is dumb and badly crippled.

We find in this institution only three negro inmates. One is a hopeless cripple, one has a bad case of locomotor ataxia, and the third is an old man who came when too feeble to work.

Is this sufficient evidence on which to base conclusions? Take another institution in the mountain section.

Here in the men's building we find an old man who has never worked and has allowed his children to shift for themselves willingly. His daughter-in-law got tired of having him around and made his son put him in the almshouse. The old man is too deaf to respond to the Binet test, but does not appear to be over nine mentally. He now occupies his time in watching Bill, a sixteen year old idiot who was brought here from the State School for the Blind. Bill has no habits of cleanliness and is insensible to pain. A little while ago he burned his feet severely by putting them on a hot stove. Even after they were burned, he did not move them until some one made him. There is no nurse at this almshouse and the superintendent and his wife are too busy to look after the helpless, so are obliged to have this work done by feeble-minded inmates.

Dick is a fourteen year old boy who tests nine, had his back broken by a fall from a tree some years ago. His parents are dead and his sisters declared that he was unmanageable, so they turned him out of the house. He doesn't know where any of his family are except a sister who works for a family in a nearby town. Another sister declared to be weak-minded, has been an inmate of the almshouse.

In the women's building we find huddled about a small stove four pitiful objects. One is suffering from senile dementia and is to be taken to the State Hospital in a few days. Another is an idiot who has been an inmate more than three-score years. It is said that her whole family were idiots. The third has softening of the brain, and has been indifferent to her surroundings for the past four years. The fourth is the only one that will enter into conversation. She talks freely about her family, but never hears from them, and cannot give their names.

In the next room we find Rosa who is thirty-three years o'd and tests seven. She is badly crippled. She says she has been treated in some hospital, but cannot tell where. Three years ago she was deserted by her husband, and since then has been in the almshouse, and likes it very much. (She is the mother of five children. The first, she says, lived only a few days, the next died at three years from "something wrong in his head," and the other children were taken by a children's society. The eldest of these was tried in several homes, proved a failure, and was finally sent to the reformatory on a charge of vagrancy. He tests a little over seven, and is fourteen years old.



Rosa's roommates are Maude and Carrie. Maude is 53 years old, is an idiot and an epileptic. An idiot brother died in a city almshouse. Maude and her sister, also an idiot, were brought to the almshouse twenty years ago. The sister died, and Maude who was in the room, did not say anything or make any sign that she knew what had happened, so the superintendent remarked, "Maude, your sister is dead." Maude grinned and said, "Aw, gimme her shoes."

Of Maude's seven brothers all save one were idiots. He got possession of the money that belonged to the others and skipped the country. The father was epileptic. One night he had a terrific seizure, and his idiot sons decided he was dead, so they carried him out into the yard and laid him on top of a grape arbor. He was old and it was zero weather, and when he was found he was frozen to death. This shows how inadequate is our present method of providing for our feeble-minded paupers.

When a child the old man was adopted by a family that moved West. In early manhood he came back to Virginia, and later married the adopted daughter of a neighbor. After several idiot children were born, it was found that the man had married his own sister. The calamity is one of many that has befallen because of lack of adequate records.

The other roommate, Carrie, is 58 years old, and has been in the almshouse over fifty years. She is an idiot and cannot tell her story, but we can get some of it from the records. We find that in 1858 an aunt of Carrie came to the almshouse. She appears on the records as an idiot. In 1859 another aunt came. She is registered as simple. Both stayed in the almshouse until they died many years ago. Of Carrie's mother we know nothing except that she had two illegitimate children who were feeble-minded. Another one of Carrie's aunts appears on the records as "simple," but she did not stay at the almshouse all the time. Although she never married she was the mother of fifteen illegitimate children, returning to the almshouse to give birth to most of them. Seven of these children died in infancy, eight were definitely feeble-minded, three of the number being idiots. One of the daughters lived in a deserted cabin on the edge of a city. She was notoriously loose morally. She died in the almshouse. Since 1858 there has been constantly at least one member of this family, and sometimes as many as five members in the almshouse.

Passing to the next cottage, we find three generations of one family. Amanda is 81 years old, and has been in the almshouse for the last twelve years. She says she has never been to school, and adds with pride that she did not send any of her children either, that she has gotten along without an education and so they could. Two of her children were born dead; three died in infancy; one was a tramp, and is said to have been killed by a fellow tramp in a western State; and another was a "dope" fiend, and died in the almshouse.

Amanda's only living child is Eva. Eva was put out to work in a family at the age of nine. At sixteen she married a man afflicted with tuberculosis. They had a hard time making a living, and while the husband was sick the two eldest children were given to the neighbors. After the father's death, the next two were given to a children's society. The

youngest, Bennie, age five, is with Eva at present. He shows signs of mental and physical degeneracy, and has not walked for several months. Apparently without a pang, Eva tells of giving up her children. She does not mind not knowing how to write, for she cannot see how it would have done her any good. Also, she says she thinks she has had a pretty good time for a poor woman, and likes it very much at the almshouse. She tests seven years mentally.

In the negro department there is a woman who tests nine. She has been keeping a disorderly house. Since it was broken up she refuses to work. Another woman, 64 years old, is helpless from paralysis. A third has had both feet frozen off, and walks on her knees. Two more women, both past eighty, have good working records, but are in the almshouse because of extreme feebleness. There are three idiots, and an insane man awaiting guards from the hospital.

The foregoing almshouses represent a rich and well populated section of the State. Let us see what the almshouses in other sections of the State look like. Here is one in a less populous and poorer section. The buildings and land are valued at \$16,000.00. The county appropriates annually about a thousand dollars for superintendent's salary and other expenses. Figuring the interest on the capital invested and adding it to this amount would make the total cost of maintenance for this institution nearly two thousand per annum. When we enter the almshouse we are surprised to learn that it contains only six inmates, and that all of them are feeble-minded. We wonder if they could not be cared for more economically in a central institution equipped to provide for the feeble-minded from every section of the State. Then we talk with the inmates.

Susie M. is an imbecile. She has been an inmate since 1886. Her loud, impatient answers soon make you ready to agree with the keeper that she is the "meanest thing on the place." Her story, extracted from her after much questioning and many rebuffs, runs as follows: She was born "the year war ended," but does not know how old that makes her. Her mother died when she was very small and she never heard anything concerning her father. The first thing she remembers clearly is going to school with the children of the persons who adopted her, and the fact that she could not learn. Later she gladly stayed at home to work in preference to going to school. When she was grown she left the home of her adoption and "lived around" a few years. At twenty-one she entered the almshouse and there gave birth to a child that died of syphilitic infection. There also she met two feeble-minded brothers, one of whom was epileptic. By each of these brothers she became the mother of a child. One child died of typhoid fever and the other was "bound out" and lost sight of. She seems to have been lacking in natural feeling, for often she used to knock the small children about and stamp upon them in unreasoning rage. Susie has not walked for five years, but manages to push her chair about the room and helps with the cooking.

Kate is epileptic, feeble-minded, syphilitic, nearly blind, and a hopeless cripple. She manages to walk around a little in spite of the fact that her body is so bent that she can raise her head and shoulders only a little

above the waistline. She has had "spells" from the time she can remember, and it is to a fall during one of these spells that her crippled condition is attributed. No doctor was called to see her—nature was allowed to take its course. Kate cannot give her family history, but a portion of it was obtained from the superintendent. It seems that she entered the institution in 1883, where she later gave birth to twins. Her step-mother whom she called "Aunt Sallie" was in the almshouse for years. She also was "simple" and had the palsy. A nephew of Kate and his half-brother (a mulatto) have also been inmates.



THE MOTHER OF TWO FEEBLE-MINDED  
CHILDREN BORN IN AN ALMSHOUSE.

Lucy Ann first made her appearance at the almshouse in 1884, and has come and gone half dozen times since. This time she has been an inmate six years, and is now helpless and "flighty." She and her sister used to indulge in drunken revels, and it was to recuperate from them that Lucy Ann frequented the institution. Lucy Ann cannot give any connected idea of her family history, and again the superintendent comes to our assistance. The woman has had no children. A sister of hers entered in 1888, but soon ran off with one of the oldest paupers and married him. In a year they were again admitted, and the man stayed until death claimed him, but the woman left and since then has managed to subsist on outdoor relief and by dint of much begging. She is regarded as decidedly feeble-minded. These women have a brother who gets out-door relief.

In the negro division we find Belle, a microcephalic idiot, age 12 years, who entered two years ago when her mother died. She is an illegitimate child. A former employer of her mother reports that the family possesses no marked defects. The neighbors attribute the child's misfortune to the fact that it was "conjured."

Lou, an imbecile who has spent a good portion of her life in the almshouse, came in 1889 with one illegitimate child, and soon afterwards gave birth to another. After years of training she has learned to do washing, and can carry meals to the helpless ones, so she is very useful. About her relatives she can tell nothing.

John has never walked nor talked, and has to be fed. Beyond the fact that he entered in 1889, and his father was known to be alcoholic, nothing is known of his history.

At another almshouse in a different section of the State, we find only four persons: an idiot who is also epileptic and has been in the institution twenty years, a paralytic who appears to be a low grade moron, and two old negro women, apparently normal. We find that after taking into consideration the interest on capital invested, superintendent's salary, and other expenses, the county is spending approximately \$1,600.00 per annum for the maintenance of four persons.

We have now seen the inmates of five almshouses. They are typical of the twenty-eight other institutions which we have given special study, and the thirty-three are representative, we believe, of Virginia almshouses as a whole. In thirty-three almshouses we have found a total population of 801, or an average population of 24.3 persons, 653 of whom are apparently feeble-minded. Of this number 253 are so decidedly feeble-minded that any one would recognize them as such, and the others are found on closer examination and inquiry into their family history and social reactions to be feeble-minded also.

One of the saddest phases of the situation is the number of children found in the almshouses—one hundred and thirty-two. Eugenists and euthenists are about agreed that heredity and environment play equal parts as determining factors in a child's life; and if approximately fifty per cent. of a child's future depends upon his environment, certainly the almshouse is not a fit place in which to raise children. Children are very impressionable; they learn by suggestion and imitation; they react quicker and have fewer inhibitions than adults. Their surroundings in the almshouse are such as to warp and twist their little lives so that they can never be straightened out again. Born amid the garbage and junk heaps of humanity, and reared in an atmosphere of failure, what can be expected of the almshouse child? Family life is to him a sealed book, school instruction often a myth; the natural avenues to normal living are closed; the joys of childhood are not his; disgrace is his heritage and failure his portion; from nothing he comes and into nothingness he sinks again. This is the fate of the normal child; what of the feeble-minded? His fate is trebly worse.

Already children's agencies are at work trying to place the normal children of the almshouse in good homes. Eventually the situation will be relieved. But the feeble-minded child will not respond to anything save special care and training—care and training such as he will not get in the



average home or institution. The only thing we can do with the high grade feeble-minded children is to try them in home after home until they either stick, or disappear. The low-grade feeble-minded we have to leave in the almshouse to grow up there where they receive no special training, and when they are grown they go out and live upon the community as parasites, burdens to the present, and menaces to the future.

We have visited the almshouse; we have seen feeble-minded women who have given birth to feeble-minded children in the almshouse and left them to burden the taxpayers; we have seen that generation after generation of the same family live and propagate their kind at the expense of the community; we have seen people who have never known any home but the almshouse and look to the taxpayer for support as their natural right; we have seen worn-out prostitutes and broken-down criminals seek the shelter of the almshouse in old age to burden the taxpayer for the rest of their lives; we have seen little children herding with the harlot, the thief, the drunkard, the epileptic, the idiot, the imbecile, the vagabond and all manner of diseased folk. Now that we have seen all of this, what are we going to do about it?

As we have already said, fully eighty per cent. of the almshouse population is feeble-minded. In verification of this, note the reactions of fifty inmates taken at random from five almshouses and tested with the Binet-Simon Measuring Scale for Intelligence. Note that 42 out of 50 reacted as feeble-minded, or 84 per cent. feeble-minded. As a further indication of their mental incapacity, you will observe that 62 per cent. were totally illiterate, 34 per cent. had received the barest of training, and only 4 per cent. had advanced as far as the average nine year-old child.

**Reactions to the Binet Measuring Scale for Intelligence in Five Almshouses**

MENTAL AGE	2	3	4	5	6	7	8	9	Normal	Total
CHRONOLOGICAL AGE										
Under 21.....	1	.....	2	2	.....	.....	4	1	.....	10
21 to 30.....	.....	1	.....	1	3	1	2	2	2	12
31 to 40.....	.....	.....	.....	1	2	1	.....	2	.....	6
41 to 50.....	.....	.....	.....	.....	.....	1	.....	4	2	7
51 to 60.....	.....	.....	.....	.....	2	.....	2	2	.....	6
61 to 70.....	.....	.....	1	.....	.....	2	2	.....	2	7
71 to 80.....	.....	.....	.....	.....	.....	.....	.....	.....	2	2
<b>Total.....</b>	<b>1</b>	<b>1</b>	<b>3</b>	<b>4</b>	<b>7</b>	<b>5</b>	<b>10</b>	<b>11</b>	<b>8</b>	<b>50</b>

84% feeble-minded.

MENTAL AGE	2	3	4	5	6	7	8	9	Normal	Total
No schooling.....	1	1	3	3	7	5	5	6	.....	31
Primary.....	.....	.....	.....	1	.....	.....	5	5	6	17
Grammar.....	.....	.....	.....	.....	.....	.....	.....	.....	2	2
<b>Total.....</b>	<b>1</b>	<b>1</b>	<b>3</b>	<b>4</b>	<b>7</b>	<b>5</b>	<b>10</b>	<b>11</b>	<b>8</b>	<b>50</b>

62% No schooling.

34% Primary.

4% Grammar.



*School Training*

The reactions of the Binet test, together with the personal and economic history and heredity of these persons, demonstrate beyond the shadow of a doubt their mental condition. And this group is but a fair sample of our almshouse inmates taken at random. Grant this, and the logical conclusion is that fully 80 *per cent.* of our almshouse inmates are feeble-minded.

The almshouse is not a suitable place for feeble-minded people. It is not equipped to give the necessary training and it does not provide adequate care. Its inmates are allowed to leave at will; the feeble-minded wander over the county; they beg, borrow, steal and practice sexual immorality; they get rid of temptations only by yielding to them; and they are constantly a burden and a menace to the community in which they tarry. Nearly all feeble-minded female inmates become mothers, thereby multiplying themselves sometimes manifold.

The wife of one of our superintendents sized up the situation as follows:

"That home you are getting for the feeble-minded women is the best thing you ever did. And if you keep on with the work, you will put all of us almshouse-keepers out of business."

At present we have \$1,141,210.00 tied up in almshouse real estate. Last year the cost of maintenance was \$212,650.39; superintendents' salaries \$29,452.00; value of crops made and consumed \$59,163.97; and interest on the real estate at six per cent, amounts to \$68,472.60; making the total cost of maintenance \$369,738.96. Counting each admission, the total population for the past year was 5,151. Now, as many of the inmates were transients, here today and gone tomorrow, persons who came and went at will, and as the number of inmates at the end of the year totaled less than 2,000, it will be safe to assume that there were 60 per cent. or over of repeaters, and that 2,000 would represent the mean between the floating and stable population for one year. Granting this, the cost per capita per annum would figure \$184.86. In an institution for the feeble-minded many of these persons can be made self-supporting, and all of the children, except idiots, now living in almshouses could be properly trained to earn their own support.

Now, if 80 per cent. of these people are feeble-minded, and if that means that 1,600 of them will be taken from the almshouses and placed in colonies for the feeble-minded, that would leave a balance of only 400 persons scattered throughout the State in the county institutions, and that means that over a million dollars would be tied up in real estate, which means that the cost of maintenance in separate institutions would be too great to retain the present system.

Although some counties seem to have solved the problem of pauperism without the expense attendant upon the maintenance of almshouses, the solution is far from being a perfect one. In one county where there is no almshouse, the poor are auctioned off to the lowest bidder, and by this means placed on a farm at moderate cost. Here the objectionable features are self-evident. Eight other counties have almshouses, but either have no paupers to inhabit them, or when they do have paupers, cause them to be provided for by the overseers of the poor from the county pension fund.



*An Almshouse Group*



*Age 19 - Mental age 3 - 3 ft. tall*



*Children in the Almshouse*



In addition to the county where the poor are auctioned off, four other counties and eight of our smaller cities have also dispensed with almshouses, the poor being cared for by organized charities or out-door relief. In none of these counties are the feeble-minded adequately provided for.

#### *Out-Door Relief.*

We have especially investigated seventy-one cases taken at random of persons provided for by out-door relief in the country; out of this number hardly more than twenty should be receiving aid in this way. There are eleven feeble-minded adults and some feeble-minded children who should be cared for, not from the county, but by being placed in an institution where they can be segregated to prevent further damage, and where they can be made to earn their own support. We have seen six cases which we class as doubtful, for although these persons own property, they are not capable of doing much work, and we haven't been able to locate near relatives in position to assist them. But do not forget that out of seventy-one cases investigated, we have found thirty persons receiving aid when there is apparently no good reason for it, and the majority of those who were entitled to aid are feeble-minded.

*The overseers of the poor receive only twenty dollars a year for their services.* Such an office carrying so small an emolument would be likely to attract only two classes of persons, philanthropists, or persons who need the money to make ends meet. A philanthropist, if he were able, would take the time to investigate each case brought to his notice; these others haven't time to do case work.

Judging from the result of our investigation, there are a few philanthropists, and a large number of persons who need twenty dollars a year to make ends meet. Many of these are good men who wish to do justice to the county and also to the applicant for relief. But they are usually busy men and cannot always spare the time to look into a case, so they take a neighbor's word for it.

Let us say that the case of Sam F. typifies others among the beneficiaries of out-door relief. Weary of the squirrel cage of ceaseless work, secure in the knowledge that if he does not shift for himself the neighbors and out-door relief authorities will shift for him, he leaves his wife and small children. So another name is added to the county pension list, the church takes up a special collection to pay the rent, and the neighbors send in baskets of food and clothing; and the family is better cared for than when the bread-winner was at work, but the method of providing for the wife and children has pauperized the family.

One of the darkest phases of the matter, however, is the fact that apparently the church, individual charity, and the county are encouraging feeble-minded women to live at large and propagate their kind. Take the case of Lucy G. Lucy is one of a large family of folks known to be "simple" and "peculiar" persons who can't seem to make ends meet and always need assistance. Lucy does farm work for a while, then discovers that she can get along without working. By and by a baby comes. Then the church, philanthropic neighbors, the secret societies, and the overseer of the poor



get to work. Lucy is very repentant and promises to do better in the future. She is tided over her illness, but her name remains on the list. Another year comes and with it a second baby to be looked after. More charity. Then a third, fourth and fifth child arrives. Lucy's parents have been helped for years; now Lucy and her children; and by and by Lucy's daughters are found to be following in her footsteps and soon there are more feeble-minded children for the community to look after. And these children in turn follow the trail blazed by some degenerate ancestor and worn smooth by numerous feeble-minded descendants. Meanwhile the taxpayer pays the price in one way or another.

The overseer of the poor should either in person or by a capable representative investigate each case for relief brought to his notice. He should get a written statement of the applicant's financial condition, whether he owns property, etc., and just why he needs relief, and how long he will require to be assisted. This can be verified by the neighborhood physician, the minister, and the district magistrate without material inconvenience. The overseer should attempt to make applicants self-supporting by securing employment for them, and to rehabilitate families if normal.

All cases of feeble-minded persons who are applicants for relief should be reported to the proper authorities, registered by them, and segregated in a colony for the feeble-minded or placed in families under adequate supervision where they will be induced to work for their living. But no one except a wealthy person can afford to do this work for \$20.00 per annum.

#### *Organized Charities.*

We have seen how legal and volunteer out-door relief, the county pension official, the citizen, and the church, work together in aiding indigent persons of rural communities, and now we come to that branch of charity which is peculiar to the city. In the city it is even more difficult than in the country to learn the actual needs of those who beg, and the number of applicants for relief is much larger; so to meet this situation charity clearing-houses have been organized, and these we call Associated Charities, which act as clearing-houses for organized charities composed of church societies and other philanthropic organizations; and the tendency is to shift upon Associated Charities the burden of testing and providing for the needs of applicants. Supported by private and public contributions, and equipped with competent workers, organized charities act as mediums of exchange by which persons in need can be intelligently helped by those who have money or its equivalent to give. Thus, although the principle of aid is in a measure similar to that employed in rural communities, it is upon a larger scale and with the difference that organized charities not only relieve the immediate physical wants of the distressed, but seek also to reform individuals and rehabilitate families.

Let us see how this work of reform and rehabilitation progresses when organized charities come in contact with feeble-minded individuals and families. We know that they do good work in cases of normal individuals and families in temporary distress, but let us see how the feeble-minded react to their methods. Looking over the records and reports of organized chari-



ties and reviewing briefly their methods, we find that very often secondary causes such as drunkenness, shiftlessness, indolence, ignorance, lack of training, improvidence, etc., have been assigned, whereas, if the truth were known, these are but symptoms of mental degeneracy, and this, the primary cause, has apparently been ignored.

Such is the case of the Y. family, four generations of which have been supported by organized charities. To begin with, a feeble-minded, alcoholic man married a woman whose mentality is unknown. To them were born six children. Month after month and year after year organized charities contributed to the support of this family; came to the aid of the mother when she was confined; assisted the father to find employment (which, however, he failed to hold); supported the family in times of unemployment; cared for it at all seasons; exercised its utmost powers to rehabilitate the family, and to reform the alcoholic and shiftless father, and to aid and direct the children and children's children. Three of the six children died in infancy, the other three were feeble-minded. One of the girls was a prostitute, and as a result of an illegal union gave birth to a diseased child which soon died. The other girl married a man of unknown mentality and to them were born two feeble-minded children. One child, a son, is now being supported by the taxpayer in an institution, and the other, a daughter, is married and has a little feeble-minded girl. All of these persons were brought under the influence of organized charities. Organized charities spent money; organized charities attempted to rehabilitate and reform; organized charities failed. Why? The only place that the feeble-minded can be successfully handled is a colony for the feeble-minded.

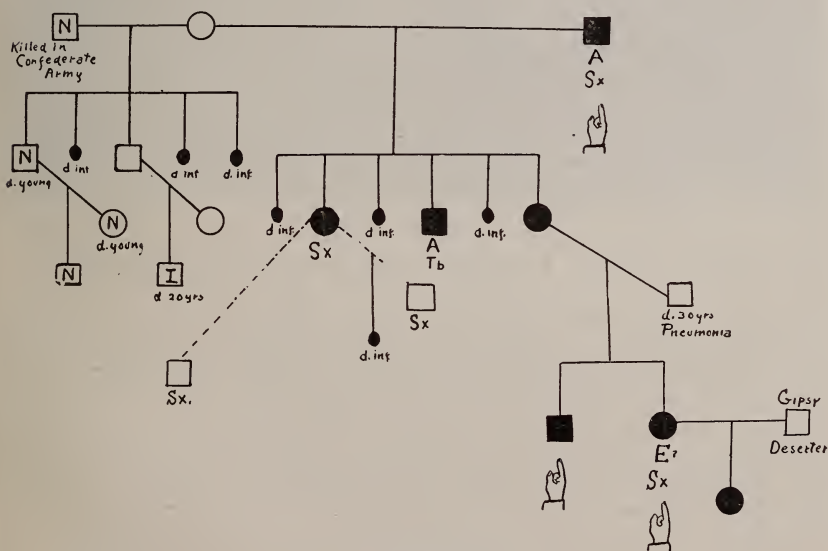

CHART 93.

## FOUR GENERATIONS CONSTANTLY HELPED BY ORGANIZED CHARITIES.

James Z., a feeble-minded epileptic, came from the country to one of our Virginia cities. He secured a job as day laborer. He married a good-looking feeble-minded girl; they raised a family. James had fits. As a consequence his various employers used to lay him off. He would be out of work for months. His family had to live, and he soon learned that if he did not support them, organized charities would. Sometimes James got drunk, and occasionally he would beat his wife. Neighbors said that she was unfaithful, and as they had a good many neighbors, being forced by irate landlords to move often for failure to pay rent, it was finally decided that the neighbors were right.



SEVEN PERSONS WERE FOUND LIVING IN THIS HUT—2 MEN, 1 WOMAN AND 4 CHILDREN OCCUPIED THE SAME BED.

And so they lived from pillar to post; when his wife was to be confined, the Instructive Visiting Nurses' Association sent a nurse, and clothes for the baby after it came into the world; a society of the Catholic Church sent provisions; the Salvation Army supplied fuel; and the Associated Charities, in return for slight services rendered by James, sent baskets of groceries. James found that things were coming his way without working, so he did not hurry about getting another job. Besides, he usually felt badly, and often had fits, and employers did not seem to desire men so afflicted. After being supported for some months in his unemployment, a job was secured for him. But he didn't stick. Soon the Instructive Visiting Nurses' Association had to send another nurse and more clothes for

a new baby, and once more the Church society and the Salvation Army and Associated Charities and kindred organizations came to the aid of the distressed ones. After the new baby had been ushered into the world and the family seemed to be getting along fairly well, James got another job, but he soon developed pains in his head and back, and after doctoring himself with whiskey without effecting a cure, the job slipped from under him. When the collector came around the rent money could seldom be found, and so James and his wife and their growing family of children moved about in the squalid sections of the city, constantly seeking aid of one or the other of a dozen charitable organizations.

Recently they were found in an old stable down near the water's edge in a state of extreme destitution. It seems that a stable helper had taken pity on the family and was now sharing his bed and board with them. James, his wife, the kindly stable man, and four children lived in the same room. There was a bed constructed of rough planks covered with old grain sacks. A dry goods box was used as a table, and tin cans served as cooking and eating utensils. The parents and children were in rags. When visited by a social worker they were all huddled up together on the bed. The stableman came in while the worker was there, but refused to answer questions, and soon left.

Once more organized charities got to work. The woman and children were taken into custody, the children as dependents, and the woman as a sort of caretaker. Employment was found for the man, and in a few weeks the family was established in rooms in a good neighborhood. While in the custody of the Juvenile Court several members of the family were subjected to the Binet test. The man proved to be 9 years mentally, the woman 10 years, the eldest child, a girl who was really nine, tested about 7 mentally, and the next child, age seven, tested four. The two younger children, aged three years, and ten months, respectively, were not tested.

For about two months the family held together, being supervised and assisted by organized charities. But it appears that the woman had lovers and her husband persisted in getting drunk and having fits or "sick spells." One night he came home drunk, accused his wife of infidelity, and beat her. He was arrested, tried, convicted, and sent to jail. This terminated his employment, and once more the family had to be supported by charity. This time, however, some thought was given to the case. A commission was held, the woman declared feeble-minded, and sent to the colony for the feeble-minded, and disposition was made of the children, one being placed in a private home, and the other three in institutions. This is the history of a feeble-minded family which for ten years has been supported by organized and other charities. The most dangerous member of the family is in a suitable institution, but it seems a pity that the man, who is lower grade mentally than his wife, though not so much of a menace, cannot be segregated instead of being allowed to run at large. A larger and more adequate colony would remedy this. But even now he could be committed as an epileptic.

Mabel W.'s parents are shiftless, degenerates who have been living for years at the expense of organized charities in Virginia and other States.

Mabel is about twenty-four, and is the mother of three illegitimate children. She is apparently a middle-grade moron, and is very attractive physically. From confinement to confinement she has received aid from various charities; in the meantime working as shop-girl and occasional prostitute. She will doubtless continue to propagate her kind unless segregated. Reform methods have been unsuccessful in her case. Organized charities have tried and failed; the colony for the feeble-minded should be the next step.

The point in these stories is that while our charitable agencies are doing invaluable work in aiding deserving cases of destitute persons who are normal, ordinary charitable agencies cannot handle with success the feeble-minded, and until the State makes adequate provision for this class of defectives, organized charities and others will have to continue to care for them at considerable expense and without reforming or rehabilitating them; that aid is apt to be misapplied and used by recipients to further their passions, and to bring into the world more of their defective kind; and that organized charities and other agencies will always meet with failure in dealing with the feeble-minded, until the State recognizes the menace, and co-operates to stamp out the evil.

#### *Summary.*

We began with a visit to the almshouses; we have seen the conditions in these institutions; we have shown pictures of out-door relief; of how the feeble-minded react to organized charities and other agencies. From these facts it is plain—

(1) Feeble-mindedness is responsible for at least 80 per cent. of our almshouse population.

(2) That our almshouses are not suitable institutions for the feeble-minded.

(3) That a large number of persons receiving volunteer and public out-door relief are feeble-minded, or are burdened with feeble-minded relatives, and that indiscriminate charity encourages such persons to live at large and propagate their kind.

(4) That relief often encourages recipients to live in vice, immorality, and indolence, and pauperizes those who might otherwise be forced to earn their own support.

(5) That out-door relief authorities and organized charities are not equipped to handle the feeble-minded, and that whenever and wherever found, the feeble-minded should be recognized as such and segregated where they will not be able to menace the public welfare and increase the taxpayer's burden.



## Chapter VII.

---

### The Relation of Feeble-mindedness to Juvenile Delinquency

A study of criminal statistics reveals that adolescence is the age when most first commitments occur, and that juvenile delinquents seem to be everywhere increasing, and crime more and more precocious. The justice of holding children equally responsible with adults has been seriously questioned, and the success of the juvenile court has given rise to a widespread recognition that children should not be dealt with on the same basis as adults. An increasing interest in child psychology and its potentialities leads to the conclusion that all children should not be held responsible in the same degree. This conclusion is based principally on evidence collected throughout the United States and Great Britain to show that many girls and boys in institutions for juvenile delinquents are mentally defective, and that methods ordinarily applied to normal children are both expensive in time and money, and unavailing in results when practiced on the feeble-minded.

The purpose of this study is to show (1) the extent of feeble-mindedness among the juvenile delinquents of Virginia, (2) what is being done for them and with what results, and (3) what should be done. With this in mind two hundred and ninety children were taken at random and examined with the Binet-Simon Measuring Scale for Intelligence in the juvenile detention homes and the industrial schools. In addition to the psychological test, other tests as to family history, personal history, social history and acquirements, moral reactions and personal knowledge, were applied. In many cases the homes were visited and parents interviewed. Appended to this article will be found the history of a few typical cases.

#### *The Extent of Feeble-Mindedness.*

Out of two hundred and ninety children tested in the Juvenile Detention Homes, and at the Industrial Schools, one hundred and ninety-seven, or 68 per cent. reacted as feeble-minded.

The children ranged in age from eight to nineteen years, their offenses from incorrigibility and vagrancy, drunkenness and disorderly conduct, to house-breaking and murder. Some had been in court as many as seven times in two years. They were not from the homes of the rich—these children. No, they were from homes in which the total income averaged less than thirty dollars a month, and in many cases this amount would seem a small fortune. They were not only from homes poor in a financial sense, but many were from homes poor in every sense—they were homes of poverty of the mentally defectives tested in the reform schools and you will drunkenness and depravity of one or both parents, and oftentimes the iron hand of an unsympathetic step-parent, had deprived the children of nearly everything that goes to make a home homelike and life bearable.



In the detention homes, out of fifty-five negro children examined, forty-six, or 84 per cent. reacted as feeble-minded; twenty-five white children out of forty-five, or 55.5 per cent., were found to be apparently feeble-minded. These children were examined as they entered the homes—taken at random.

At the Laurel Industrial School, out of a population of 235, one hundred boys ranging in age from eleven to nineteen years were examined with the Binet test. Fifty-seven were found to be feeble-minded, and in addition, eleven tested one to three years backward. Ninety boys out of a population of 169 were tested at Hanover (the Negro Industrial School) and sixty-nine, or 77 per cent., reacted as feeble-minded. Seven more tested one to three years backward.

*What is Being Done for Them and With What Result*

A group of one hundred backward children tested in the detention homes had in their brief careers been charged with 179 offenses, forty-six being repeaters and responsible for 70 per cent. of the offenses. At the time of examination they were waiting to be tried and disposition was made as follows:

Committed to	
State Board of Charities and Corrections.....	56
Industrial Schools .....	15
Juvenile Protective Society .....	5
Colony for the Feeble-minded .....	1
Epileptic Colony .....	1
Children's Home Society of Virginia .....	1
Other Institutions .....	2
Dismissed .....	8
Fined .....	2
Whipped by parents .....	2
Returned to relatives .....	2
Probationed .....	5
	100

Following up these cases, we find that of the 56 children committed to the State Board of Charities and Corrections, a new disposition was made as follows:

Committed to	
Children's Home Society of Virginia.....	3
Jewish Institute .....	1
Mountain School .....	1
Industrial Schools .....	4
Placed in private homes .....	47

The three children committed by the State Board of Charities and Corrections to the Children's Home Society were placed in private homes. One is doing well, one has run away, and the third has been tried in two homes without success. The two latter children reacted to the Binet scale as feeble-minded. No complaint has been received in regard to the children placed in institutions. Of the forty-seven children placed in homes, 12 are doing well, 2 fairly well, 7 have not been reported on and 28 have given trouble in one way or the other; one feeble-minded child has been tried in six homes without success. In other words the children who fail to make good in family homes under supervision are the feeble-minded children. These 28 children all tested feeble-minded by the Binet scale and later by their reactions to normal living conditions have confirmed the findings of the psychological test and demonstrated that methods ordinarily applied to normal children with success, often meet with failure when tried on the feeble-minded anti-social child. These are the children from whom the criminals of the next generation come. Segregate and train them to be self-supporting and the delinquent population of coming generations will be proportionately decreased.

#### *What Should Be Done.*

An inquiry into the school history of juvenile delinquents reveals what one might expect, *i. e.*, in the school mental backwardness first manifests itself outside the home circle, and there it should be taken in hand. The fourth grade is the great falling-off place for the majority of them.

There are three institutions in which the feeble-minded can be detected early in life: the school, the juvenile court, and the reformatory. The school presents the best opportunity, for there they can be treated and trained before the initial experience in delinquency, and often it is there that the first symptoms manifest themselves. In the juvenile court, and it may be after a career of crime, the defective delinquent can be recognized and dealt with according to his mentality. But when he reaches the reformatory, it may be already at the expense of the happiness of friends and relatives, and perhaps a drain on the community purse. Examine the history of the mentally defectives tested in the reform schools and you will find that the public school has failed, probation has failed, placing in private homes has failed, and that as a last resort they are sent to the reformatory—and that in too many cases will fail. Why? Simply because they are mental defectives and will not respond to the treatment given normal persons.

To detect the feeble-minded at the starting of the roads, all children in the schools suspected of being backward, and all children convicted in the juvenile courts should be given a psychological test, and their family histories, social and moral reactions noted. They should then be dealt with according to their mental responsibility. Both in the public schools and in the reformatories, classes for backward children should be organized, and when it has been proven conclusively that a child is feeble-minded, he should be reported to the proper authorities. (See appendix.)

*After the Reformatory, What?*

Too great emphasis cannot be placed upon the organization of classes for backward children in the juvenile reformatories. The question in regard to reformatory inmates is: After the reformatory, what? What is to be their fate? The critical time is when a boy or girl leaves the institution to begin life in the world. He has gotten accustomed to the routine of institution life. The discipline has shaped in his mind certain habits which he automatically obeys. It will be hard for even the normal boy to readjust himself to the world as he finds it. He may enter the same old environment, or there may be no home to which he can return; he may find that most of his friends, or all of them, have moved away. He must take things as he finds them, make new ties, and whatever environment he enters and whatever ties he forms will be determining forces in his life. Even if he is a normal boy he will have a difficult time reinstating himself in society. If he is feeble-minded, he will inevitably drift back to the channels which brought him to the reformatory—for the feeble-minded are drifters all—he will again make the acquaintance of the courts; he will go to jail to take lessons in crime in that public school for criminals which the State so unwittingly maintains; and after the jail, perhaps to the penitentiary. Or, after a career which has proven costly to the community; after he has been sent to jail, on various charges ranging from "miscellaneous worthlessness" and drunkenness, begging and vagrancy, to petty larceny and kindred offenses, he will in his old age wind up in the city or county almshouse to be supported there for the balance of his worthless life. All his life he will have been a burden and a drag on the community. And if he has tried to raise a family that family will, in turn, be supported by the community, and will live on through the generations to breed other feeble-minded and criminalistic persons.

*Summary.*

To summarize, the fact that 68 per cent. of the children passing through the Detention Homes and in the Industrial Schools are feeble-minded emphasizes the need of specific action with regard to them. The feeble-minded should be detected in childhood. The first place to detect them is in the schools; next in the juvenile courts, and then in the reformatories. Each child suspected of being feeble-minded or backward, should be given the Binet test and his family history and social and moral reactions noted, and he should be dealt with according to his mental responsibility. At the juvenile reformatories classes for backward children should be established. We should ascertain which are feeble-minded, and when a feeble-minded boy leaves the reformatory he should leave it only to go where he will receive custodial care, either in an institution or in a private home, where he will be recognized for what he is, and treated accordingly—where he will be made to earn his own support and will not be allowed to propagate his kind.

*Some Typical Cases.*

*Marie. Age 13. Mental age 7.*

Marie, a short, stout girl with a dull, uninteresting countenance, when tested did not know her age nor the name of the place she came from. She

seemed very apathetic and answered in monosyllables. Physically she appeared to be about fourteen, although she tests half that age. Placed out in six homes she failed to make good, although in all she was well treated, and in one home she had exceptional care under a lady especially fitted to train such cases. Not only was she densely stupid, but likewise immoral. Persisting in her immorality she was given up as hopeless, and returned to the court. Finally she was sent to the reform school. It is to be hoped that by the time she is ready to leave the school the colony for the feeble-minded will be ready to receive her. Otherwise, Marie will be but another recruit for the underworld.

*John. Age 15. Mental age 8.*

John could not learn anything at school and would not work. He was a congenital loafer. He was convicted of vagrancy and committed to the State Board of Charities and Corrections. A good home in the country was found for him, but he either could not or would not—anyway, he did not, appreciate it, and soon ran away. Twice he was recaptured and placed in suitable homes, but, preferring the company of tramps to a civilized existence, each time he escaped and joined his friends. The third time he was more successful in hiding, and is now very probably a regular in the army of "bums." Eventually he will reappear in some arc of the vicious circle—the jail, the penitentiary, or the almshouse.

*Tom. Age 17. Mental age 10.*

Tom is the unfortunate son of an alcoholic father and a mother of questionable reputation. The boy stammers and is very nervous. Twice he has been convicted of petit larceny, but allowing for heredity and environment he was each time given another chance. During the past five months he has been tried in four homes, but seems unable to adapt himself to the change of environment. His future is problematical. Unless he can be segregated and trained he will probably be a drifter for the rest of his days. And the drifter is one of the taxpayer's many burdens.

*Bud. Age 15. Mental age 9.*

Bud is a chronic trouble-maker. He has been in the juvenile court five times, three times for fighting and twice for larceny. On probation he reported regularly for a while, but stopped when it suited his convenience, and did not show up again until brought in by an officer for fighting. After probation had been tried several times without marked success, he was committed to the State Board of Charities and Corrections. He was placed in a private home in the country where there was plenty of good food and enough work to keep him out of mischief. Accustomed to having his own way when at home, he resented the discipline of farm life, and rebelled. A few weeks later he was found back at home. Three times after this he was placed in good homes, but failed to respond to the demands of normal life, and each time ran away after a short while. Later he was arrested in the city for stealing a watch, was tried, convicted, and as a last resort, was sent to the reformatory.



*Myrtle. Age 15. Mental age 9.*

Myrtle seems to have been born without a chance. Her mother a prostitute, she seems to have been foredoomed to follow in her footsteps. Any way at thirteen Myrtle was a street walker, and before she was fourteen had served four jail sentences for this offense. She was finally sent to the reform school. There she rebelled against the unaccustomed restraint, and tramped to the nearest city where she entered a house of ill-fame. Three days afterwards she was found and carried back to the school. When questioned concerning her lapse of morality she seemed to be entirely unashamed; on the contrary, appeared to regard it as a matter of course, and not out of the normal way of living. After the reform school, what?

*Billy. Age 15. Mental age 8.*

Billy was brought into court on a blanket charge of being incorrigible. His parents claimed that he persisted in lying and stealing, and was absolutely beyond their control. He was tried on probation. That failed. He was placed in a good home. He ran away. He was finally sent to an industrial school where he has given trouble. And the end is not yet.

*Clifton. Age 15. Mental age 10.*

Clifton was in court the first time for murder, but as there appeared to be lack of motive, a verdict of accidental killing was brought in. However, as the boy was found to be out of school and in bad company most of the time, he was placed on probation as a preventative and possible reformatory measure. He soon violated his probation and was brought into court the second time. His parents were simple persons of low mentality and claimed to be afraid of the boy. They wished him sent to the reformatory, but as the boy begged for another chance and promised to behave himself in future, he was placed in a private home in the country. His old habits claimed him after a short while, and back to the city he came. He was recaptured and brought into court, and upon his promise to do better, was given another trial in the country, but with the same result—when an opportunity presented itself he skipped out and returned to his old haunts. He was recaptured and carried to the detention home. He was sullen and made vague threats, but the keeper paid little attention to them. Somehow the boy managed to secrete a revolver and awaiting his opportunity attempted to escape. The keeper blocked his path. Other prisoners ran out in the hall to see what was the trouble. The boy drew his revolver and fired at the keeper, but his aim was bad, and the bullet pierced the forehead of a girl prisoner who was in the line of fire, killing her instantly. The next five years Clifton will spend in the penitentiary. When he gets out he will still be as much, if not more, of a menace to the community than when he was committed.

Other cases could be cited which show the futility of half measures in dealing with mental defectives, but in the main they only duplicate some of the stories given, and juvenile delinquency like adult criminality, moves in circles, and history repeats itself in the chronicles of feeble-mindedness as in other things.



## Chapter VIII.

### The Relation of Feeble-mindedness to Prostitution.

*As Shown by a Study of the Segregated District of a City in Virginia.*

All students of mental deficiency who have investigated to any great extent the causes of prostitution are of the opinion that feeble-mindedness is a principal factor in the supply. Investigations have been made from time to time in various parts of the United States with the idea of ascertaining the relation of feeble-mindedness to prostitution, with varying results. The Chicago Morals Court had 639 prostitutes examined, and found the proportion of feeble-minded to be 62%. At another time 126 prostitutes were examined by the same investigators, and the proportion reacting as feeble-minded was 85.8%. Of 104 sexually immoral girls, tested in the Illinois Training School for Girls, 97% reacted as feeble-minded. The Massachusetts vice commission examined 300 prostitutes in three groups of 100 each: (1) young girls just beginning prostitution; (2) women plying their trade in the streets; and (3) women who were old offenders. The mental defect of 154 prostitutes, or 51%, was so pronounced as to warrant their legal commitment to custodial institutions for the feeble-minded. The report of this commission states that the women in this group came from shiftless, immoral, and degenerate families; they were industrially inefficient, as shown by the low wages received, and by their inability to retain a position, even in unskilled callings, they were very deficient in judgment and good sense; they lacked ordinary general knowledge and practical information, as well as ability to perform simple computations or to read or write, except in the most elementary way.

A study of 243 women made by the Massachusetts Reformatory for Women showed 49% to be defective mentally, 16.5 % very dull, and 47 out of the remaining 84 cases showed other defects, such as epilepsy, hysteria and psychopathic tendencies. Only 15% of the entire number appeared normal mentally and physically. In this group of cases were included all women in the institution in whose history there had been at any time a period of commercialized promiscuous sex immorality.

The chief objection raised to the foregoing studies is that, except in the Massachusetts investigation, most of the women tested were in custody, which might seem to indicate that as mental weakness was responsible for their failure to make a living in legitimate callings, so also it had lessened their chances of keeping clear of the law, and this might suggest that the vast majority of those who escaped must of necessity be keener intellectually, and, therefore, groups examined in custody would not be typical of the army of prostitutes plying their trade at large.

Such an objection could not, however, be applied to conclusions based on an investigation of an entire district of prostitutes; hence this study, we feel, will throw a more practical light on the subject.

Through the courtesy of the chief of police, the investigator, escorted by a police officer, visited the houses of the prostitutes, and later conducted examinations at police headquarters, where the women were summoned from time to time as required. The Binet-Simon Measuring Scale for Intelligence was used, and in addition supplementary information was obtained as to personal knowledge, family and social history, school and economic history, etc.; all of which information was verified so far as possible by field workers in subsequent research. As 23 of the women were raised in the city studied and 35 others had their homes in neighboring Virginia cities and counties, the social workers were able to do more field work than is usually possible in such investigations. In addition to this follow-up work, the secretary of the Board of Charities and Corrections was, through his position as member of the vice commission, enabled to study the district, and later, when it was closed, he, acting for the board, was instrumental in providing transportation to their homes for about one hundred of the women, which gave him further opportunity for study. The supplementary information thus secured was not available at the time figures obtained in the preliminary survey were made public, but the tables given now in this study are presented only after a careful revision made in the light of the additional data referred to.

*The Correlation Between Chronological and Mental Ages of One Hundred and Twenty Prostitutes.*

MENTAL AGE	CHRONOLOGICAL AGE				
	Under 20	20-30	31-40	41-50	Total
6.....		1			1
7.....		1	2		3
8.....		9	2	1	12
9.....	1	23	1	1	26
10.....	1	19	3	1	24
11.....	2	18			20
Normal.....		27	5	2	34
Total.....	4	98	13	5	120

Feeble-minded..... 71.6%  
Normal..... 28.4%

*Classification as to Imbeciles and Morons*

Imbeciles (7 years and under mentally).....	4
Morons (up to 12 years mentally).....	82
Total.....	86

## Classification as to Previous Occupation

OCCUPATION	Imbeciles	Morons	Normal	Total
Factory hand .....	2	37	11	50
Shop girl .....		6	4	10
Waitress .....		5	1	6
Housemaid .....		1	3	4
Laundress .....	1	3		4
Housekeeper .....			1	1
Scrub woman .....		2		1
Farm hand .....		2		2
Stenographer .....			2	2
Under-graduate nurse .....			3	3
Sewing woman .....		1	1	2
Tailoress .....			1	1
Manicurist .....		2		2
Trapeze performer .....		1		1
Show girl .....		1		1
Cashier moving picture show .....		1		1
Institution attendant .....		1		1
Telephone operator .....			1	1
Milliner's assistant .....		1		1
Secretary to doctor .....			1	1
Demonstrator .....			1	1
Never employed .....	1	19	4	24
<b>Total</b> .....	<b>4</b>	<b>82</b>	<b>34</b>	<b>120</b>

*School History.*

This information as originally tabulated was obtained from the women, and in attempting to verify it subsequently, the field workers found it to be so inaccurate that it is not presented here. As evidence of the large percentage of illiteracy among these women, however, when the district was closed and nearly a hundred of them applied at the office of the Board of Charities and Corrections for transportation and aid, fully fifty per cent. were unable to write their names, and the majority of the others could barely read and write.

*Marital Relations.*

Of 29 women, 23 were married under the age of 21. Of 40 marriages, 24 women lived with their husbands less than two years; 12 less than one year. With reference to those in houses of prostitution before and after marriage, 22 became prostitutes after marriage, and 11 were married from houses of prostitution.

Of 100 women reporting, 14 children were born to unmarried women, and 46 children to married women. There were in this group 53 unmarried and 47 prostitutes who had been married.

*Reasons Assigned for Entering Life.*

Of 25 women giving reasons for entering life of prostitution, 10 assigned economic necessity; 5 "because I wanted to;" 2 ran off with a show; 4, bad companions; 2, betrayed and deserted; 1, husband went with other women; and 1, tired of working. The disregard for consequences, the inability to choose the right line of conduct, the lack of self-control and of foresight shown here, all are marked characteristics of the feeble-minded.

*The Girls That Went Wrong.*

Josie was born of a defective father and normal mother. Left an orphan at an early age, it was in the school department of an institution for dependent children that she first manifested signs of feeble-mindedness. Tried out in many private homes, she failed to "make good," and was finally allowed to enter the home of a married sister, where she remained but a short time. At a tobacco factory she secured work and soon drifted into fast company; as a consequence, she lost her good name and position and eventually entered the segregated district.

Two sisters, Bettie and Dolly, are from a family of twelve, some feeble-minded and others doubtful cases. The father is regarded as "shiftless and simple;" the mother, feeble-minded. The two girls left school after reaching the fourth grade. The mother says, "Bettie and Dolly wanted finer clothes than we was able to give them, so they stopped school and went to work." While working their maximum wage was \$4.50 a week. Their industrial history presents an old story of incompetency and irregularity, which is accounted for by the fact that the girls were meeting men each week. After a time they lost their positions, and soon entered the red-light district. Their parents, when interviewed, seemed to view the girls' state with apathy.

Sallie's father was shiftless, immoral, and a drunkard. He seems to have been unable to make a living and his children had to rely mainly on their mother and the neighbors for support. Upon the death of their mother, the children were scattered about in homes and institutions. Sallie was sent to live with a relative in the city. There she attended school for a while, but she "wasn't bright and couldn't learn." She was allowed to stop school and go to work. After an unsuccessful marriage she became an occasional prostitute, and later entered a house of prostitution.

Madge seems to be the product of generations of in-breeding of neuro-pathic strains. There is evidence of a large incidence of feeble-mindedness, insanity, "queerness," etc., with some criminality in her family for generations back, and her parents, brothers and sisters appear to be decidedly feeble-minded. She was married at an early age and divorced by her husband because of gross immorality. She has lived in houses of prostitution in Raleigh, Norfolk and Richmond. In Richmond she was expelled from several houses for drunkenness and theft, and has been in jail a number of times. A thief, drunkard, prostitute, the mother of an illegitimate child, and the potential mother of others of her kind, she is a menace to the morals and health of any community in which she lives.

In addition to these cases, twenty-five others were investigated and in every instance the investigator found evidence in the personal and family history of the girls which corroborated in the main the findings of the Binet scale.

*Summary.*

According to the Binet scale, 71.6% of prostitutes plying their trades in the segregated district of the city reacted as feeble-minded, and inquiries into their family history substantiate the findings of the psychological test.

The logical conclusion is that feeble-mindedness is esponsible in large degree for the waywardness of these women, and that they should not be punished for doing that which their heredity made almost sure; but society should segregate them where they will be protected from licentious men and lewd, avaricious women; where they cannot harm others and may, in a measure, redeem themselves. Place them in a colony and they can there earn their own support, put money into the State treasury instead of being a constant loss, directly or indirectly, both on the pocketbook of the taxpayer and the health and morals of the community; for not less than a million dollars is worse than thrown away in Virginia in prostitution every year, and the prostitute, wherever she may be, is a center for the spread of venereal disease.



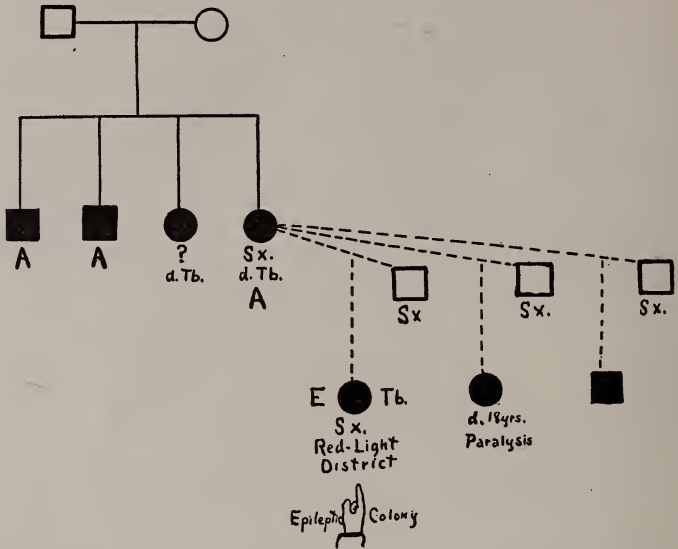

CHART 54.

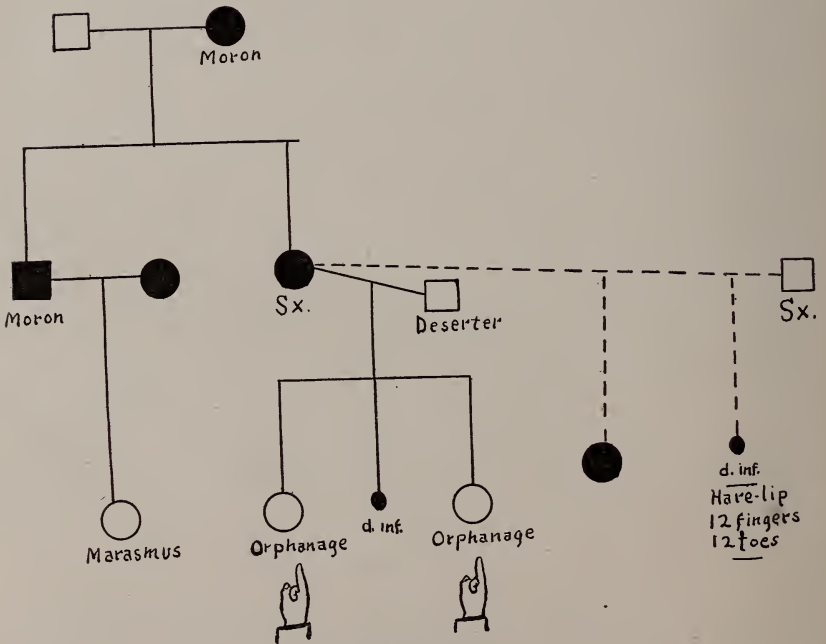

CHART 58.

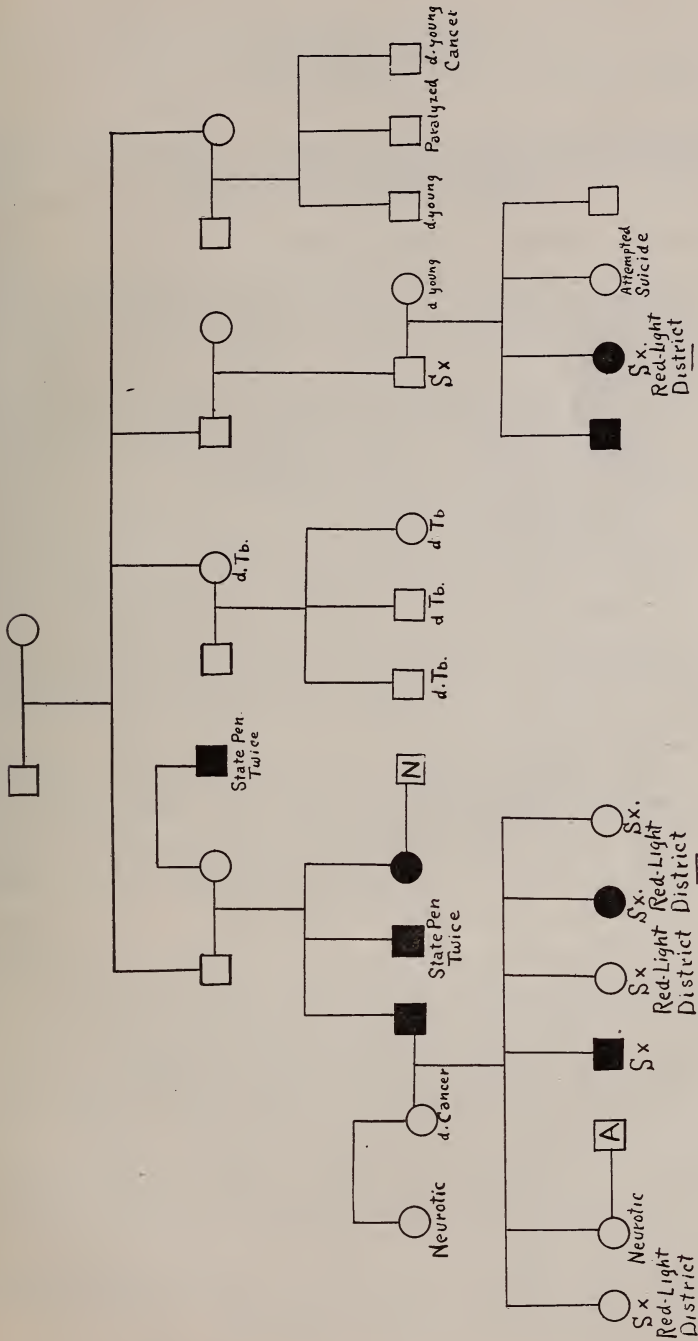

CHART 59.

# Chapter IX.

## The Relation of Feeble-mindedness to Crime and Drunkenness and the cost thereof.

*As Shown by a Study of the Jail Population of a Virginia City.*

Jail prisoners are our greatest prison problem because they outnumber any other class, and live in enforced idleness at a cost of nearly \$400,000.00 per annum, while the taxpayer works to support them.

Commitments to jail in the State of Virginia for the fiscal year ending September 30, 1914, aggregated 26,384.

The maintenance, et cetera, of jail prisoners for the past year cost the taxpayers of Virginia \$397,883.51.

This expense is increasing yearly.

The jail neither reforms prisoners, nor, as a rule, deters them from a repetition of delinquency; instead, it is a veritable public school of crime in which prisoners are learning vice, immorality, and crime, and are degenerating both physically and morally.

Over 60 per cent. of the jail population is made up of feeble-minded and other permanently anti-social persons who practically live in jail most of the time, and will burden the taxpayer either in jails or other institutions with themselves and their families as long as they live.

In a suitable institution jail prisoners could be made to earn their own support and thus an unnecessary burden would be lifted from the back of the taxpayer.

On a State farm for defective delinquents and city farms for ordinary short time prisoners both classes can be made self-supporting. The proof is on Virginia soil.

As a representative group of delinquents for a study of the relation of feeble-mindedness to crime and drunkenness and the cost thereof, the jail population of a certain Virginia city for a definite three years' period was chosen. It was decided that the most practicable manner in which to make this study was to take the card index records of individual prisoners on file in the office of the State Board of Charities and Corrections, made up from the city sergeant's reports, and sort out the "repeaters," or those prisoners who in three years' period were recorded as inmates of the City Jail from two to twenty-four times, and with these in hand proceed to—

1. Get from the police court and hustings court records complete information as to the crimes for which they were committed and the punishment meted out to them;
2. Compute the cost to the city and State on account of loss of fines and expense of maintaining jail prisoners in idleness;

3. Test as many as practicable by the Binet-Simon Measuring Scale for Intelligence to determine the percentage of feeble-minded;
4. Ascertain the personal and industrial history of typical cases;
5. Draw then from the data collected such conclusions as would logically and naturally follow.

It was with these steps in mind and with a full appreciation of the importance of getting sufficient and reliable data on which to base conclusions that the work was undertaken and completed.

*The Jail Population.*

The jail population of the city chosen, was, for the period of this study (October 1, 1910, to September 30, 1913.) 8,371. Of this number 223 commitments were for insane persons confined in jail pending the arrival of guards from the State Hospitals. Subtracting this from the total would leave a net population of 8,148. Of this number 3,214 person's names appear on the jail records only once during the three years' period. This period, however, is only a small slice cut out of the lives of these individuals, and a scrutiny of police court and jail records prior to and since the space of time in question, reveals the fact that approximately 50% of them are actually repeaters, but as we are dealing with a period only, for the purpose of this study they will be termed "one-timers." Of "one-timers" there were committed for

Misdemeanor .....	2,993 or 93%
Felony .....	221 or 7%
	Total.....3,214

Naming "repeaters" there were commitments amounting to 4,934, or 60% of the total population. 1,425 persons are named in the 4,934 commitments, making the average of commitments per person three and five-tenths. Of "repeaters" there were committed for

Misdemeanor .....	4,734 or 96%
Felony .....	200 or 4%
	Total.....4,934

*Comparison of Arrests with Commitments.*

The chief of police's reports covering the period of this study show arrests as follows:

White—Male .....	12,169		
Female .....	818	12,987	39%
		Total.....	
Negro—Male .....	16,210		
Female .....	4,106	20,316	61%
		Total.....	33,306

Comparing this total with the total of commitments it will be noted that 25% of persons arrested were committed to jail, and as against 39% whites and 61 per cent. negroes arrested, 30 per cent. whites and seventy per cent. negroes were committed to jail. On a basis of sex it is interesting to note that eighty-five per cent. males and 15 per cent. females were arrested, and eighty-two per cent. males and 18 per cent. females were committed to jail. (See tables 1 and 2.)

*Definition.*—The word "crime" as used here is taken in its looser sense to imply "all acts punishable by fine or imprisonment, or both," and not necessarily meaning a felony. As the jail population, which is composed of ninety-five per cent. misdemeanants, is the subject of this study, naturally more attention is devoted to crime of the misdemeanor class, or petit crime. It will be noted (by referring to tables) that such crimes have been divided into three classes: I. Against the Person. II. Against Property, and III. Against Public Order. A felony being commonly regarded as a "penitentiary crime," although not always resulting in a penitentiary sentence, felonies are not divided into classes, but are shown collectively.

*One-Timers.*—Note that Table I of delinquent men and women in jail one time during the period of October 1, 1910, to September 30, 1913, is compiled from the jail records studied. The law does not require the city sergeant to keep a detailed record of offenses and this accounts for the paucity of information.

Tables in repeaters' cases are based on information derived from both jail and court records, and are, therefore, more complete and accurate.

*Repeaters.*—Note that with the exception of Table 2 each table represents as to times a certain definite class, *e. g.*, Table 3 of two-timers contains none but those who have been committed two times and two only. Table 4 of three-timers contains none but those who have been committed three times and three only. Multiply the number of times by the number of persons in each table and you get the correct commitments.

#### *Class I. Crimes Against the Person.*

By referring to Tables 2 and 16, it will be noted that crimes against the person are responsible for only 9.3 per cent. of commitments in repeaters' cases. Analysis shows that Assault and Battery and Wife or Woman Beating are most prominent in number, Contributory Delinquency and Indecent Assault being almost negligible; and that negroes were responsible for ninety per cent. of the crimes of this class. From the standpoint of sex, no white women were jailed for offenses of this class, and only 13.6 per cent. negro women. It will be noted that only one white man and two negro men were jailed for contributory delinquency, and that three negro men were responsible for the total number of indecent assaults. Tables 3 to 15, inclusive, show analysis of cases in further detail, and it might be interesting to note the fluctuations, for instance, how in Table 6, negroes outnumber whites 34 to 1, in Table 7, negroes 20 to whites 4, in Table 8, whites disappear entirely, only to reappear in the next two tables, and again disappear in the following two tables.



*Class II. Crimes Against Property.*

Crimes against property, as per Tables 2 and 16, show 12 per cent., and analyzing this class into its parts, one notes petit larceny 364, suspected of petit larceny 103, and trespass 126. Note that the responsibility for commitments in this class is divided as follows: White males 15.5 per cent., white females 00.17 per cent., negro males 70 per cent., negro females 14.33 per cent.; total for whites 15.67 per cent., negroes 84.33 per cent. It will be noted that negroes were responsible for 87 per cent. of petit larcenies, and classifying them as to sex shows that to the males were due 91 per cent., negro females only 9 per cent., and that no white females in repeaters' cases were committed for petit larceny.

"Suspected of petit larceny" is a term liable to criticism. In these cases the police court docket reads as it usually does in petit larceny cases, the difference in the punishment is that instead of being a flat jail sentence the suspect is required to furnish bond for good behavior, or go to jail. The background to these cases is such as to warrant strong suspicion of guilt, and even though the police justice is not convinced by the evidence that the prisoner is guilty, he may suspect him of being guilty and to prevent further suspicious actions on his part may in the interest of preventive justice demand surety, in default of which the prisoner is sent to jail.

"Trespass" charges usually read "with intent to commit larceny." Note that 104 negroes and 22 whites were guilty of trespass. Trespass and larceny, likewise, trespass and vagrancy, are closely related.

*Class III. Crimes Against Public Order.*

This is the largest class, constituting 73.4 per cent. of the whole. Analysis shows (as per Tables 2 and 16) white males 34 per cent., white females 00.15 per cent., negro males 47 per cent. and negro females 18.85 per cent.; as to color only, whites 34.15 per cent., negroes 65.85 per cent.; as to sex, males 81 per cent., females 19 per cent. Two of the largest items in this class are drunkenness 1,618, and disorderly conduct 1,122. These two offenses are closely related; disorderly conduct, while it may be only a blanket charge for a multitude of minor offenses, masks probably 80 per cent. of cases of one-drink drunk, one-fourth drunk, one-half drunk, and so on, *e. g.*, a man who takes enough drinks to make him quarrelsome and otherwise disorderly or to cause him to go home and break up the furniture, yet be able to walk without staggering. On the other hand, a case of drunkenness, to be a finable offense under the city ordinance, is almost invariably, either in the police stations, or after the "cue" sheet is received in police court, entered on the docket as "drunk and disorderly." "Drunks" are divided into two classes, the "disorderly" and the "peaceable" drunk. Peaceable drunks are those unfortunates who have imbibed too much to take care of themselves and yet do not fall below the minimum of lawful behavior. The police corral them in the station houses to protect them against pickpockets and the elements until they are sober and then release them, no charge being entered on the books. From 1,500 to 2,000 "peaceable" drunks are taken care of annually.

The chief of police's reports show arrests for drunkenness (October 1, 1910, to September 30, 1913), as follows:

Males .....	4,899 or 90%
Females .....	496 or 10% 5,395

Police court records, as per Tables 1 and 2 show that these arrests resulted in 2,678 committals, or fifty per cent., from which it would appear that one-half of the people who are brought in police court charged with drunkenness are committed to jail. However, it will be seen further on that a few individuals can in the course of three years be responsible for quite a number of commitments. It is a singular thing that drunkenness is the assigned cause of 66.3 per cent. of commitments of white male repeaters, and 75 per cent. of white female repeaters, while in case of negro male repeaters it figures only 18 per cent. and negro females 25 per cent.

Note (Table 2) that only three white males were committed for carrying concealed weapons, as against 46 negro males and two negro females, and in cruelty to animals the negroes outnumber the whites 23 to 2. Note that in fornication negroes lead by an overwhelming majority, 73 to 3, and that it is about evenly divided between the sexes.

There is room for speculation in the fact that no white repeaters were jailed for gaming, while 209 negro males and 4 negro females were committed. In keeping resorts for gaming, the negroes are also in a vast majority, 30 to 1. Note that for keeping houses of ill-fame 2 white females, 1 negro male and 14 negro females were committed. For non-support, or neglect of family, 13 negroes and 9 whites were jailed. In all other offenses against public order the negroes predominate over the whites, for example: Promoting policy, negroes 3, whites 0; selling liquor without license, negroes 20, whites 3; speeding automobile, negroes 3, whites 0; street-walking, negro females, 146, white females, 5. Vagrancy and begging are more equally divided between the races, but as to sexes the record shows 247 males to 15 females.

#### *Felony.*

Only 4 per cent. of repeaters were felons, as per Tables 2 and 16, while it will be seen by Table 1 that felons number 7 per cent. of one-timers. As the majority of felons are confined in jail only while awaiting trial, or guards from the penitentiary or road camps, they are really not jail prisoners proper, and as the average term for which they were committed was two years and 63 days, it will readily be seen that this class could not have done much "repeating" in the three years' time under examination. This probably accounts for the disparity in above percentages.

Note (Table 16) that felony is distributed as follows: Negro males 80 per cent., and negro females, 12 per cent., that white males were found guilty of only 8 per cent., and white females of none; and as to sex, negro and white males 88 per cent., negro females 12 per cent.

*Suspected of Felony.*

This unclassified item foots the list with 1.3 per cent. In these cases the police court docket sometimes charges a felony, without specifying the class, and then again reads "Suspicious character, suspected of felony," hence no analysis or classification could be made. The verdict in cases entered here as "suspected of felony," was invariably so many dollars surety for so many days, and to jail in default. Note the analysis: negro males 67 per cent., negro females 23 per cent.; white males 10 per cent., while no white females were committed under suspicion of felony.

*Punishment.*

By referring to Table 20 it will be noted that 91 per cent. of jail prisoners proper were committed in default of fine and surety, fine only, or surety only; in other words, because they owned neither money or property, and had no friends to go their security. Strictly speaking they were not criminals. But because they were poor and friendless they were detained in jail and treated as criminals. Only 9 per cent., or those convicted of minor felonies and petty larceny, were actually criminals, and yet the punishment is the same for both. For instance, a man is convicted of being drunk and disorderly. He is fined. He is poor and cannot pay. He is committed to jail for ten or fifteen days in default. Or, maybe, he is required to give security for 20, 30, 60 or 90 days and goes to jail in default. Another man is found guilty of petit larceny or a minor felony. He is sentenced to jail, as the records will show, 15, 20, 30, 60 or 90 days. If the "drunk" is an old offender he is probably required to give \$100 security for six or twelve months, or go to jail in default. Sometimes he is sentenced to the roads for a like period. The thief or felon, if he be an old offender, will likewise suffer an increase of punishment in the same ratio. And the drunkard, although he may have never injured any one but himself, although he may never have taken other people's money or property, finds himself undergoing the same punishment as the habitual thief and felon.

*The Fining System.*

The old theories of punishment have not stood the test of modern practice, and one by one they are being abandoned. One theory we still cling to, and which seems the most difficult to relinquish is the fining system. It is rooted in the fee and spoils system, and will die hard, but it must go eventually. Here is how it works: Bill Bruteson gets drunk and beats his neighbor. He is arrested and brought before the police justice who says: "I am sorry to see you here, but you have violated the law and, therefore, you must be punished. Pay me five dollars or I will have to send you to jail for ten days." Bill cannot pay, and so he goes to jail. Now, as you well know, people cannot be fed and lodged in jail without expense, so the effect of the sentence is that if Bill does not pay to the police justice five dollars out of his own pocket, the taxpayer has to go down into his pocket and pay the jailer five dollars. And Bill's neighbor, being a taxpayer, has to contribute a portion of this. Bill is injured by

being sent to jail; his neighbor is injured in the first place by being assaulted and in the second by having to pay for his assailant's board and lodging, and if Bill's family happens to be in want, his neighbor, directly or indirectly, is injured by having to contribute towards their support; and to cap the situation, the police justice fails to collect the fine. Here's where the trouble is: Bill is not the only one that has to pay. But to offset this, as the theory goes, when he gets out of jail he is supposed to have expiated his offense. Let's see if he has. To sum up his history: He got drunk; beat his neighbor; was fined five dollars; couldn't pay; then he was sent to jail and there confined in enforced idleness ten days. How does spending ten idle days in jail expiate the offense? Is Bill any better off? No, because he has been idle when he could have been at work; he has, perhaps, received a lesson in vice, immorality or crime from a past master, and on the whole, he is decidedly worse off than when he entered jail. Is Bill's neighbor any better off? No, for in addition to nursing his injured feelings he has had to help support the man who assaulted him. If Bill keeps the peace in future, maybe something has been accomplished; it may be that by this he can expiate his offense; but a jail sentence is not calculated to rouse feelings of peace and amity, and so the issue is doubtful and expiation much of a myth.

Looking at the matter from another angle, had Bill been a man of means, he might have beaten his neighbor, or committed any one of a large number of offenses without risk of imprisonment. So, it appears that the fining system is nothing less than a licensing of anti-socially inclined persons to break the law. And even in this the license does not always fall equally on the licensee. For instance, two men appear in court charged with speeding, or reckless driving. One is an autoist, the other a delivery wagon driver. The autoist is fined one hundred dollars. The driver of the wagon is fined ten dollars. To the one the fine represents only a small inroad on his means, while to the other it represents more than a week's wages. The autoist can furnish bond and take an appeal and in a higher court the fine will probably be reduced to twenty-five dollars. The driver most likely hasn't the money to pay his fine nor can he find any one so unwise as to go his bond, so he goes to jail.

#### *The Jail as a Reformatory Institution.*

No one has ever been so foolish as to contend that our methods of dealing with jail prisoners make for their reform. It may be that some classed as "one-timers" have been checked in their career by the treatment they received, but as a matter of fact, many of them never ought to have been sent to jail at all. They could have been just as well handled on probation. The cost to the taxpayer would have been less; the result on the offender would have been more for good than ill; and all parties concerned would have been better off.

Instead of being reformatory, jail methods tend to the making of criminals, as exemplified by the large number of repeaters. It is true that the jail takes the offender off the street for a space of time, and prevents him from annoying those at liberty; but this method is extremely expensive, and



when the offender is released the chances are that he will repeat the offense, soon get the jail habit, spending the majority of his days in idleness at the taxpayers' expense, and finally, in old age, drift to the almshouse to be supported there by the taxpayer until his worthless life dribbles out. Half the money it costs to keep prisoners helpless in jail for wrong-doing, if spent in helping them to help themselves towards right-doing, would prevent many of them from offending again. But this can never be done so long as we cling to the jail system.

*The Jail Is a Deterrent.*

The mere fact that 60 per cent. of jail commitments during the short space of three years is accounted for by *repeaters* is in itself *prima facie* evidence that the jail as a deterring influence against crime is sadly lacking in power. By increasing the time period to six years and studying the same records, it could, doubtless, be demonstrated that fully 80 per cent. of our jail population is made up of individuals who come and come again.

By referring to Tables 17, 18 and 19, it will be noted that repeaters not only repeat, but repeat in the same offense over and over again. Drunkards repeat in drunkenness, thieves repeat in petit larceny, street-walkers repeat in street-walking; and they all mix other offenses with these. It is evident that the kind of punishment meted out to them has no deterring influence. Table 17 shows that one individual was committed 18 times for drunkenness in three years, and that 346 individuals were responsible for 1,333 commitments, or 82.4 per cent. of all commitments for drunkenness. Table 18 shows that one man was committed five times in succession for petit larceny, five men four times in succession, nine men three times in succession, and that 53 individuals were responsible for 35 per cent. of the total commitments for this offense. Table 19 shows that one woman was in jail 10 times in three years for street-walking, and that 33 women were responsible for 71 per cent. of the total number of commitments for this offense.

In each class of crimes or offenses, the punishment each time involved spending a certain period, ranging from ten days to twelve months in jail. Each time a released prisoner contemplated committing a new offense, the thought of returning to jail did not deter him. After the first commitment he has been branded as a "jail bird" and has gotten used to the stigma, so the stigma is no deterrent. After the first time he doesn't mind so much, and although he may repeat eight times or ten times a year, the repeated lessons in confinement do not deter him from committing other offenses after the termination of this series of sentences. No; not even repeated lessons in confinement act as a deterrent. *Why?*

Because: The repeater occupies a low level, mentally and morally. He doesn't reason as clearly as the man of average intelligence who manages to keep out of jail. It will be noted further on that 64 per cent. of repeaters are sub-normal, or feeble-minded. The others although re-acting as normal, are anti-social persons, some of them confirmed in anti-social habits and, therefore, they do not think and act normally; for the normal man is social and resents anti-social conduct. To the feeble-minded and other anti-social



persons the jail appeals because they know that there they may rest and recuperate from their excesses.

Although the street-walker may show a slight improvement in physical condition, the confinement does not improve her morally. On the contrary, what she did not already know about her trade she probably learns from an older fellow prisoner.

The drunkard may temporarily eliminate the drink demon, but nothing is put in place of it, and when he goes forth from jail, the devil and all his brethren with renewed ardor are waiting for him to again occupy his life.

The thief having nothing else to do, learns from a fellow thief new tricks in the trade, and is, therefore, a little cleverer with his next job.

And the vagrant, after having deteriorated physically, and therefore morally, and perhaps learned a few lessons in crime, goes forth and tries his hand in a new game of getting something for nothing.

Far better it would be that they should occupy themselves as did the criminals in the old English prisons, who simply had to carry iron balls from one corner of the prison court to the other, to heap them up and then carry them back—even this would be better than idleness. It is true that *that* is now considered cruel punishment, but it kept their muscles toned up—it kept them from degenerating physically, and therefore, it kept them from disintegrating morally as rapidly as they might otherwise have done; it helped to checkmate criminal activity; for with them physical idleness means criminal activity. With nothing else to occupy their time they busy themselves inventing criminal ideas, which will upon their release explode like bombs against the pillars of society. But in the light of our civilization we do not need to hark back to medieval methods. We have something better to offer.

#### *Feeble-Mindedness as a Cause of Crime and Drunkenness.*

To ascertain the extent of feeble-mindedness among jail repeaters, one hundred prisoners were selected at random from the list of 1,425, and tested with the Binet-Simon scale. At the time of selection no attention was paid to the nature of their delinquency records; but to gain a fair idea of the mentality of their respective races, whites and negroes, irrespective of the nature or degree of their offenses, were chosen in equal proportions. In addition to the psychological test, however, reactions were obtained to supplementary tests as to family, personal, and social history, social acquirements, economic efficiency and personal knowledge, and each individual was identified with his recorded criminal history. An examination of the results reveals that by chance the proportion of drunks and criminals tested is 50 per cent. each, and that among the drunks are numbered 34 whites and 16 negroes, while the criminals include 16 whites and 34 negroes. Therefore, while conclusions as to the respective percentages of the feeble-minded among the races would be unquestioned, when it comes to deducing that the level of mentality of inebriates in general is higher or lower than the mental level of criminals, thoroughly accurate conclusions could not be based on the number tested, but in the main the results are fairly indicative.

As a result of these tests (see Table 21), it has been ascertained that 64 per cent. of the repeaters examined are feeble-minded, i. e., they possess a mentality lower than that of a normal twelve year old child, according to the Binet-Simon scale, and their reactions to the life of the social group in their respective communities confirm the findings of the psychological test.

It was borne in mind while giving the test that adults, as a rule, react more slowly to the Binet test than children, and accordingly more time for reactions was allowed. And in case of the negro adults, it was observed that they reacted more slowly than the white adults. This also was taken into consideration and due allowance made. This answers any criticism that might be offered and which might be invited when one notes that while the whites tested only 50 per cent. sub-normal, the reactions in the case of negroes showed 78 per cent. to be sub-normal.

Tabulating them in two general classes of "drunks" and criminals, it will be noted that the former appear to be on a higher mental level than the latter; for instance, "drunks" tested 58 per cent. sub-normal, while the criminals reacted 78 per cent. sub-normal. One might argue from this that the drunkard stands on a higher mental level than the criminal. In favor of this argument, note that only 44 per cent. of white inebriates reacted as sub-normal against 62 per cent. of white criminals. But opposed to it is the fact that the negroes tested as to "drunks" 87.5 per cent. sub-normal and criminals 73.5 per cent. sub-normal, with the balance slightly in favor of the argument. However, as before suggested, the number of each race tested as to mentality in relation to the character of delinquency is regarded as insufficient evidence on which to base accurate conclusions.

Bear in mind though, that out of one hundred repeaters, 64 reacted conclusively as sub-normal persons, and assuming this to be true, figuring on this basis there are more than nine hundred repeaters who will never be able (on account of mental defect existing from birth or an early age) to conduct themselves with prudence enough to keep out of prison, and who will always fail to respond favorably to methods of reform ordinarily applied to normal delinquents. Therefore, for these persons special provision should be made either in a colony for the feeble-minded or on a prison farm for misdemeanants. The rest of the repeaters should also receive treatment better than the jail system affords, where they can be made to pay for their own maintenance, and will have an opportunity to reform.

As has been stated in the foregoing, 91 per cent. of jail prisoners are not criminals in the strictest sense, for they would not have been in jail had they possessed foresight enough to have had on hand a few dollars or the equivalent in credit. Therefore, the difference between the majority of jail prisoners and the police court delinquents who pay their fines seems to be one of foresight. One has it and the other has it not. And lack of foresight in such an extreme degree is one of the chief characteristics of the feeble-minded. Take a mental snapshot of the life of a feeble-minded man. Foresight has not controlled his birth—he is born to feeble-minded parents who raise one child a year of his stamp—he is brought up in a squalid environment. His parents haven't foresight enough to provide a better one.

He goes to school. He finds it difficult to learn. At the first opportunity he drops out and goes to work. His parents haven't foresight enough to see the error of this, and they need the money. Being unskilled and backward as a worker, the boy earns little. He gets discouraged. He leaves his job. He remains in idleness for a while and gets another. He hasn't foresight enough to stick to one thing. He hasn't foresight enough to prepare for the future. He drifts from job to job and finally in a period of unemployment temptation comes, he reacts to a criminal impulse, the inhibition comes too late. He yields and is caught. He hasn't had foresight enough to make friends who have foresight. He hasn't had foresight enough to save a little money. So for lack of foresight he goes to jail. Therefore, lack of foresight makes him, in the eyes of the law, a criminal.

Here follow some cases selected as typical of how sub-normal delinquents react to life, and showing that institutions with which they come in contact fail to check them in their anti-social careers.

#### *Typical Cases.*

*Case IX.—E. W. Chronological age 24; mental age 11.1.*—E. W. was born of a neurasthenic father and normal mother. When E. W. was a young child his father committed suicide. As the boy grew older his mother noticed the same nervous peculiarities in him that his father had exhibited. Sometimes at the table he would stop eating, assume a faraway look, then his face would gradually lose all expression, and for 48 hours thereafter he would be extremely nervous and become intensely irritated if any one spoke to him. The boy attended public school until he was fourteen when he stopped to go to work. His teachers said he gave little trouble, but seemed incapable of learning, and could barely read and write when he left school.

When about sixteen E. W. began drinking, and as drink always accentuated his nervousness, making him fighting mad over the smallest trifle, he soon landed in jail. His mother married again and when his step-father tried to take him in hand the boy rebelled and left home. During the past eight years he has been in jail in Richmond and other cities a good many times, usually for drunkenness and disorderly conduct.

E. W. tried job after job; once he worked two years at a trade, but for some unascertained reason he quit and shifted to another place. Finally he started to work as an apprentice painter and learned his trade. He has never worked steadily since that time. Excellent opportunities have been thrown his way, but he has persistently refused to take advantage of them. During the three years of this study his record shows as many as fifteen commitments to one jail.

His heredity, his school record, his personal and social history, together with his industrial history and the reactions of the Binet test lead us to believe that E. W. is a high grade moron. At present he is a burden on any community he chooses as his abiding place, and he will doubtless burden the State either in jail or other institutions the remainder of his life. Therefore, he should be taken in charge and put where he can be made to earn his own support.

*Case X.—W. H. Chronological age 28. Mental age 8.1.*—W. H. was

born of ignorant illiterate parents in a squalid quarter of Richmond. His father is said to have betrayed comrades in a labor riot trial, and to have fled here to escape their wrath. For several years he lived on money alleged to have been sent him as the price of betrayal. Since living in Richmond he has never worked regularly, dividing his time, as a rule, between drinking and fighting and going to jail. Two weeks before he died of tuberculosis, he was in jail. Of W. H.'s mother little is known except that she is said to have been a good woman, but very simple.

As a boy W. H. was the constant companion of his father, he received no schooling—says he never was in a school in his life—and doesn't know how to read or write.

W. H. seems to have followed the line of least resistance invariably. Imitating his father's example he early began to drink and carouse. He committed numerous small thefts against his companions, and as they refused to appear against him he was not prosecuted. Growing bolder, he stole from outsiders and landed in jail for a six months' sentence. Prior to this he had made the acquaintance of the jail as a result of sprees, and his aged mother had paid his fines. She soon grew tired of this, however, and stopped coming to his rescue. He now averages eight times a year in jail, sentences varying from ten days to six months. In three years he has spent only about thirty days out of jail. His jail record, beginning when he was about seventeen, and extending over a period of eleven years, shows that he has been committed not less than sixty times, and he has been in police court at least one hundred times.

When about twenty, W. H. married into a family which has been costing charitable organizations of this city an average of \$100 per annum. No children have resulted from this marriage, and for the past few years he has not been living with his wife, who, it is said, bears a reputation no better than his.

As a workman W. H. has never earned over \$1.50 per day, and that as an ordinary day laborer. One of his former employers says he has known W. H. for ten years, who came to work for him as a boy of seventeen or eighteen and worked off and on for five or six years in a spasmodic fashion. Had to be watched all the time as he wasn't "overbright" and made a good many mistakes. As soon as he received his pay he would disappear for a week, a month, or sometimes six months. Was constantly getting in trouble; as soon as he got a drink or two in him would quarrel and fight with the first man that came along.

W. H.'s parents, or at least one of them was a moron, and W. H. unmistakably belongs to this class. According to the Binet-Simon Measuring Scale for Intelligence he is only 8.1 years old mentally. Or, in other words, he is a child with the stature and passions of a man. His heredity is bad, his personal and criminal history show that he is habitually anti-social, that he has never been able to take care of himself, and will burden the community as long as he lives, either in jail, the penitentiary, or some other institution supported by the taxpayer. His record in police court and jail shows that he is costing the taxpayer annually, as follows:



In uncollected fines .....	\$ 60 00
Maintenance in jail .....	90 00
Economic loss of time (idle in jail).....	177 50
Total.....	\$ 327 50

Assuming that this is a fair average for the eleven years during which he has been coming in contact with the law, the total cost for the period would be \$3,602.50.

Had the boy of seventeen come into contact with the right kind of institution upon his initial experience in delinquency all this could have been saved. If the man of twenty-eight is not taken in charge by the State and sent to a proper institution the cost will continue to mount up. In an institution for the feeble-minded he may yet be useful to the taxpayer instead of an ever-increasing burden, for when at work he earns \$1.50 a day, when in jail he costs the State 25c. a day. The true economic loss in his case is, therefore, \$1.75 a day, less board and clothing.

*Case XI.—B. J. Age 38. Mental age 8.3.*—His parents never succeeded in raising themselves above the poverty line, and consequently the environment afforded their son was unfavorable. He could not learn his A B C's, so they did not think it worth while to keep him in school. He played around in the gutter until old enough to work, and then got a job in a factory. It seems that he soon grew tired of labor, and tried "bumming" for a while. This landed him in jail. He early started the alcoholic route to oblivion, and this together with the jail habit, seems to be about the only line of vocation he has persistently followed. He claims to have worked in many places around town, but can name only one—the last job. There he worked only two weeks, and was "fired" for loafing.

B. J., when examined, could not name the day, nor the month, nor tell within seven years what year it was. He could not name but six months of the year, nor give any four months in consecutive order. He failed to answer questions of comprehension which the average child of nine finds easy.

For the past twenty years he has spent most of his time in jail on charges ranging from drunkenness and disorderly conduct to vagrancy, begging, and petit larceny. And in spite of his repeated offenses, he has been receiving at the hands of justice the same treatment for his mental and moral sickness year in and year out, with no chance of cure. Figuring the economic loss, court expenses, maintenance in jail, etc., he has cost the State at least \$6000.00 already, which is a rather large doctor's bill when there is no hope of being cured by the treatment. On a prison farm for misdemeanants or in a colony for the feeble-minded he could at least be made self-supporting, and perhaps more, instead of a perpetual source of expense to the taxpayer.

#### *The Cost.*

Turning to the State Auditor's reports, we find that the total expense to the State of prisoners in the jail in question for maintenance and trial





### DOES JAIL LABOR PAY?

The answer is on Virginia soil. The District of Columbia is saving \$80,000 per annum by working jail prisoners on the farm at Occoquan, Va.



expenses was for the period of this study \$112,141.01. After allowing for clipped sentences and the time of penitentiary, reformatory, roads and asylum prisoners, the cost of maintenance figures as follows:

298,805 days at 25.1c .....\$75,000 00

The cost of maintaining repeaters, on a basis of the above, would be \$45,000.00 for the three years in question. Fines and costs in repeaters' cases for this period, assessed but not collected, amounted to \$32,128.15. Just how much of this is the State's loss and how much the city's loss, is, under the present system of distributing fines, hard to arrive at, but it is apparent that the taxpayer has lost all of it.

Granting that the economic value of prisoners is 50 cents a day over and above their own support (at the lowest estimate) the taxpayers of Virginia have lost on account of repeaters, which, as has been stated, constitute 60 per cent. of the jail population, as follows:

Cost of maintaining repeaters in jail 179,883 days at 25.1c per day..	\$ 45,150 63
Loss of economic value of repeaters 179,883 days at 50c per day..	89,941 50
Loss on account of fines, assessed but not collected.....	32,128 15
Total.....	\$167,220 28

As this last item would, under a prison farm system, have been absorbed by taking advantage of the economic value of the prisoners, the actual loss could not be placed at more than \$135,092.13, or \$45,030.71 per annum in one city jail.

It has been shown that 64 per cent. of repeaters are feeble-minded, and since the loss on account of repeaters being maintained in idleness amounts to \$45,030.71 per annum, take 64 per cent. of this and you have the loss occasioned by maintaining the feeble-minded in idleness in the city jail in question, which is \$28,819.65 per annum. The number of jail prisoners for 1914 in Virginia was 26,384. In the same proportion the total loss to the State occasioned by present methods of handling the feeble-minded in jail would be \$277,386.78 per annum—enough money to purchase and equip two farms the size of the District of Columbia Prison Farm.

#### *A Possible Solution.*

Were the economic side of the question the only phase to be considered, the argument here and now in favor of a colony for the feeble-minded on a larger scale, and a prison farm for misdemeanants is well worth considering. By committing the feeble-minded delinquents to the feeble-minded colony where they would not be allowed to propagate their kind, and by committing other repeaters not classed as feeble-minded, but found by repeated offenses against society to be anti-social, to a prison farm for misdemeanants on an indeterminate sentence, the State would save in this one city \$45,000 per annum, which is the interest on \$750,000.

Aside from the immediate gain (and by immediate gain is meant the

gain to be derived within several years' time), the potential saving should be taken into consideration. If anti-social persons, both feeble-minded and normal, are allowed to continue as they are now trending, the debt future generations will have to pay will stagger humanity. We shudder when we think of the Jukes and the Kallikaks and the Tribe of Ishmael, the degeneracy that has resulted and the millions of dollars it has cost the taxpayers of other States; but right here in Virginia we have our own Jukes, and our own Kallikaks, and our own Tribe of Ishmael, and now is the time to act.

*A Prison Farm for Misdemeanants.*

It has been argued that although the employment of prisoners to do prison work may be justified on other grounds, it cannot be defended on an economic basis. The fact that our penitentiary and State farm and road camps are self-supporting answers this argument. It has been argued that a prison farm for misdemeanants would not pay as so many of the prisoners are sentenced for such a short time, and that although it may be possible for long time prisoners to pay for themselves, short time prisoners could never be made to do so. The answer is on Virginia soil. Sentences of misdemeanants committed to the District of Columbia farm are from three days to two years, the average sentence being thirty-five days, and yet the farm pays. The average in the city jail studied is 54 days. Under the old system misdemeanants were costing the District of Columbia an average of \$100,000.00 per annum. The average cost per annum during the four years the prison farm has been in existence is less than \$20,000.00 per annum—a saving of not less than \$80,000.00 per annum, and the authorities say that in a few more years the farm will not only be supporting the prisoners, officers, guards and families of non-supports, but will be able to give aid to the distressed families of the majority of prisoners. The District of Columbia Commissioners think so well of the farm idea that they have recently purchased another large tract of land adjoining the present farm, and will establish there reformatory institutions to handle felons, instead of sending them with federal prisoners to Atlanta and Leavenworth.

One disadvantage they are now laboring under is the fixed sentence. Here is what the superintendent, Mr. W. H. Whittaker, says about this:

“A fixed sentence, such as the courts are now compelled to give to those who violate the law, and especially those who have short terms, such as 15 or 30 days, is the cause of much of the crime and vagrancy committed in the District. I recommend that the criminal code be so amended that prisoners committed to the workhouse should be sentenced for a period of not less than 30 days nor more than two years, the time of release to be vested in the Commissioners of the District, depending upon the ability of the prisoner to maintain himself as a self-supporting and law-abiding citizen.

Until we have a law giving us time to study the crimes and causes for which prisoners are sentenced we will not be able to use the best methods to correct and return to society at least 60 per cent.

of those who come to us, as self-supporting and law-abiding citizens. There is nothing like the work test to bring out the best that is in an individual, and it is this system we have inaugurated at the work-house. With the indeterminate sentence we will be able to steadily and persistently apply the method, until we will be able to determine just when the individual is ready for parole. The fellow who has a constitutional aversion to industry will soon reveal his true character under this form of treatment, so we may easily know him and put him in a class, under proper discipline, where he may be self-supporting while in the institution, but if permitted to go at large would at all times be a source of annoyance and expense to the community where he may go. It is not necessary, even with this class of subjects, to humiliate or degrade them. It is far better to inspire and encourage them. With an indeterminate sentence we will have time to give them a few months of wholesome diet, with regular habits, honest work, sanitary buildings in which to be housed, and clean clothing to wear; and many of those apparently hopeless subjects can be made into better men and women. It is possible through proper discipline and constant work to arouse in the lowest type of humanity confidence and self-respect."

Here is another argument for an indeterminate sentence: If the third conviction felon is deemed incorrigible to such an extent that he must be confined for life, why shouldn't the misdemeanor convicted for the third time be committed on an indeterminate sentence to a suitable institution where he will be under observation and can be discharged when in the opinion of the authorities in charge he reforms?

In our present system of dealing with the delinquent class it seems that we do much of our best work at the wrong end. We are careless in handling beginners in crime; we slur over their cases without considering either the mentality of the prisoner or the background to his offense; we commit a man to jail if he cannot pay his fine; we give him a start penitentiary-wards, and then after we have succeeded in getting him there, we clothe him better, feed him better, and house him better than we do in jail. If we were as intelligent in our treatment of the beginner in crime as we are in dealing with the incorrigible, we would get much better results. We can point to our penitentiary and State farm with pride, for they are efficiently managed institutions. The penitentiary has as its slogan: "We want our institution to be the best of its kind in the United States." The jail—well—the jail has no slogan save its insidious voiceless appeal to the anti-social.

#### *Summary.*

1. Our method of dealing with misdemeanants is doubly wrong—socially and economically. Socially, because (a) punishment is not adjusted to the peculiar character of the delinquent and is meted without due consideration to his mental condition, e. g., repeaters constitute 60 per cent. of the jail population and 64 per cent. of repeaters are feeble-minded; and (b) the jail as a correctional process does not correct, but, on the contrary, re-



sults in increasing delinquency, e. g., the large number of repeaters. Economically, we err in allowing prisoners to remain idle in jail at the expense of the taxpayer when they could be made to earn their own support in an institution suited to their mental and physical capacity.

2. Not enough attention is being paid to cases of young offenders, first offenders, and petty offenders. The background of each case should be carefully studied, and punishment should take into consideration both the good of the individual and the weal of society. This class of delinquents should be tried on probation and left in freedom conditioned upon future good behavior, and in cases of fines they should be allowed to pay in instalments. A man should not be branded a criminal because he is poor and cannot pay his fine at the time of trial. In case of repetition of their misdemeanors delinquents should be sent to an appropriate institution with indeterminate sentence, to be detained until considered worthy of reinstatement in society.

3. The jail as an institution is neither reformatory nor deterrent, but is more in the nature of a public school of crime, vice and immorality; it is not only an anti-social institution, but is a ruinously expensive one, and, therefore, it should be abolished and a more humane and economical system adopted in its stead.

4. As the prison farm exerts a reformatory influence and as it can be made self-supporting by utilizing the labor of short time prisoners, it should be substituted for the jail system.

NOTE: Over a year ago the city council of Richmond appropriated \$23,000.00 for the purchase of a city farm to be used instead of the jail. As yet Richmond has no city farm.

Lynchburg is the only city in the State that has taken advantage of the new law. The city council of Lynchburg appropriated \$5,000.00 for the purchase of land. A four hundred acre tract was purchased on the Lynchburg and Durham Railway, seven miles from Lynchburg. Also, an additional appropriation of \$5,000.00 has been made for equipment. A one-story frame building has been erected, and this contains offices, dormitories, dining room, kitchen, etc. Ninety-six men have served sentences ranging from fifteen to ninety days since the farm began operation, and in spite of the fact that there are no bolts or bars, locks or barbed wire stockade, or other prison features which might seem to prevent escapes, and despite the fact that there are no guards at night, and men can come and go at will, there have been only five attempts and but two escapes. Only one punishment has been found necessary—the man was put to work breaking rock. As the necessary equipment is installed, and other buildings are erected, the population will be added to until the jail is entirely empty. Under the new law (Chap. 333, Acts of Assembly, 1914,) the same general arrangement as to fees and expenses allowed to jailors prevails. But now the State is reaping advantage from the economic value of prisoners, and causing them to be self-supporting, instead of losing not only the cost of maintenance, but their economic value also.

TABLE 1

## Delinquent Men and Women in Jail one time

During Period October 1, 1910, to September 30, 1913.

White—Men .....	934	
Women .....	43	977
Negro—Men .....	1,689	
Women .....	548	2,237
Total .....		3,214

CRIMES	WHITE		NEGRO		Total
	Male	Female	Male	Female	
Drunkenness .....	574	32	381	73	1,060
Petit larceny .....	59	3	209	41	312
Fornication .....	14	4	48	52	118
Other misdemeanors .....	235	3	904	361	1,503
Felony .....	52	1	147	21	221
Total .....	934	43	1,689	548	3,214
PUNISHMENT					
Committed to jail in default of fine and surety, fine only and surety only—87.5% .....	820	39	1,297	486	2,642
To jail—flat time sentence—12.5% ..	82	4	238	51	375
Total .....	902	43	1,535	537	3,017
Committed to jail pending the arrival of guards from:					
The penitentiary .....	26		100	11	137
The public roads .....	6		8		14
The Negro Reformatory ..			46		46
Total .....	32		154	11	197

N. B.—The above table was compiled from jail reports.

TABLE 2

Total of Repeaters—Two to twenty-four times each in Jail

During Period from October 1, 1910, to September 30, 1913

White—Men .....	345	
Women .....	12	
		357
Negro—Men .....	837	
Women .....	231	
		1,068
Total .....		1,425

CRIMES	WHITE		NEGRO		Total
	Male	Female	Male	Female	
<i>1. Against the Person</i>					
Assault and battery .....	33		274	61	368
Contributory delinquency .....	1		2		3
Indecent assault .....			3		3
Wife or woman beating .....	13		72		85
<i>2. Against Property</i>					
Petit larceny .....	48		283	33	364
Petit larceny, suspected of .....	23		60	20	103
Trespass.....	21	1	73	31	126
<i>3. Against Public Order</i>					
Carrying concealed weapon.....	3		46	2	51
Cruelty to animals .....	2		22	1	25
Disorderly conduct .....	188	3	655	276	1,122
Drunkenness .....	945	40	454	179	1,618
Fornication.....	2	1	38	35	76
Gaming .....			209	4	213
Gaming, keeping resort for .....	1		26	4	31
House of ill fame, keeping .....		2	1	14	17
Non-support (neglect of family) ..	9		13		22
Promoting policy .....			3		3
Selling liquor without license.....	3		19	1	23
Speeding automobile .....			3		3
Street-walking .....		5		146	151
Vagrancy and begging .....	111	1	137	14	263
Felony.....	16		163	21	200
Felony, suspected of .....	6		43	15	64
Total.....	1,425	53	2,599	857	4,934

Commitments—

White—Men .....	1,425	
Women .....	53	
		1,478 30%
Negro—Men .....	2,599	
Women .....	857	
		3,456 70%
Total.....		4,934

TABLE 3

Delinquent Men and Women in Jail two times

During Period from October 1, 1910, to September 30, 1913

White—Men .....	161	
Women .....	5	166
Negro—Men .....	456	
Women .....	104	560
Total .....		726

CRIMES	WHITE		NEGRO		Total
	Male	Female	Male	Female	
<i>1. Against the Person</i>					
Assault and battery .....	15		78	19	112
Contributory delinquency .....	1		1		2
Indecent assault .....					
Wife or woman beating .....	4		19		23
<i>2 Against Property</i>					
Petit larceny .....	20		91	9	120
Petit larceny, suspected of .....	8		14	7	29
Trespass .....	8	1	30	8	47
<i>3. Against Public Order</i>					
Carrying concealed weapon .....	2		20		22
Cruelty to animals .....	1		8		9
Disorderly conduct .....	68	2	262	78	410
Drunkness .....	154	3	125	33	315
Fornication .....			19	14	33
Gaming .....			89	2	91
Gaming, keeping rescri for .....	1		10	2	13
House of ill-fame, keeping .....				9	9
Non-support (neglect of family) ..	4		6		10
Promoting policy .....			1		1
Selling liquor without license .....	2		6		8
Speeding automobile .....			2		2
Street walking .....		4		14	18
Vagrancy and begging .....	27		37		64
Felony .....	6		82	7	95
Felony, suspected of .....	1		12	6	19
Commitments .....	322	10	912	208	1,452

TABLE 4

## Delinquent Men and Women in Jail three times

During Period from October 1, 1910, to September 30, 1913

White—Men .....	55	
Women .....	3	58
Negro—Men .....	169	
Women .....	42	211
Total .....	269	

CRIMES	WHITE		NEGRO		Total
	Male	Female	Male	Female	
<i>1. Against the Person</i>					
Assault and battery .....	4		61	9	74
Contributory delinquency .....			1		1
Indecent assault .....			1		1
Wife or woman beating .....	4		19		23
<i>2. Against Property</i>					
Petit larceny .....	8		57	5	70
Petit larceny, suspected of .....	5		11	4	20
Trespass .....	3		15	5	23
<i>3. Against Public Order</i>					
Carrying concealed weapon .....	1		5		6
Cruelty to animals .....			3		3
Disorderly conduct .....	29		129	45	203
Drunkenness .....	97	8	74	24	203
Fornication .....	2		12	7	21
Gaming .....			45	1	46
Gaming, keeping resort for .....			7	2	9
House of ill-fame, keeping .....	1		1		1
Non-support (neglect of family) ..			2		2
Promoting policy .....	1		1		1
Selling liquor without license .....			8	1	9
Speeding automobile .....	1		1		1
Street-walking .....				14	14
Vagrancy and begging .....	7	1	15		23
<i>Unclassified</i>					
Felony .....	4		30	6	40
Felony, suspected of .....	1		9	3	13
Commitments .....	165	9	507	126	807



TABLE 5

## Delinquent Men and Women in Jail four times

During Period from October 1, 1910, to September 30, 1913

White—Men .....	38	
Women .....	1	
		39
Negro—Men .....	99	
Women .....	30	
		129
Total .....		168

CRIMES	WHITE		NEGRO		Total
	Male	Female	Male	Female	
<i>1. Against the Person</i>					
Assault and battery .....	4		44	11	49
Indecent assault .....			1		1
Wife or woman beating .....	1		13		14
<i>2. Against Property</i>					
Petit larceny .....	6		45	5	56
Petit larceny, suspected of .....	3		16	3	22
Trespass .....	3		11	4	18
<i>3. Against Public Order</i>					
Carrying concealed weapon .....			9		9
Cruelty to animals .....			3		3
Disorderly conduct .....	25	1	100	33	159
Drunkenness .....	91	1	54	29	175
Fornication .....			3	3	6
Gaming .....			23		23
Gaming, keeping resort for .....			3		3
House of ill-fame, keeping .....		1		1	2
Non-support (neglect of family) .....	5		2		7
Selling liquor without license .....			1		1
Street-walking .....		1		29	30
Vagrancy and begging .....	10		28		38
<i>Unclassified</i>					
Felony .....	2		26	1	29
Felony, suspected of .....	2		14	1	17
Commitments .....	152	4	396	120	672

TABLE 6

## Delinquent Men and Women in Jail five times

During Period from October 1, 1910, to September 30, 1913

White—Men .....	13	
Women .....		13
Negro—Men .....	45	
Women .....	12	57
Total .....		70

CRIMES	WHITE		NEGRO		Total
	Male	Female	Male	Female	
<i>1. Against the Person</i>					
Assault and battery .....	1		24	2	27
Wife or woman beating .....			8		8
<i>2. Against Property</i>					
Petit larceny .....	3		21	1	25
Petit larceny, suspected of .....			7	1	8
Trespass .....	2		6	3	11
<i>3. Against Public Order</i>					
Carrying concealed weapon .....			2		2
Cruelty to animals .....			2		2
Disorderly conduct .....	12		51	24	87
Drunkenness .....	42		57	12	111
Fornication .....			1	3	4
Gaming .....			21		21
Gaming, keeping resort for .....			2		2
House of ill-fame, keeping .....				4	4
Non-support (neglect of family) .....			1		1
Promoting policy .....			1		1
Selling liquor without license .....			1		1
Street-walking .....				6	6
Vagrancy and begging .....	3		13	4	20
<i>Unclassified</i>					
Felony .....	1		5		6
Felony, suspected of .....	1		2		3
Commitments .....	65		225	60	350

TABLE 7

## Delinquent Men and Women in Jail six times

During Period from October 1, 1910, to September 30, 1913

White—Men .....	20	
Women .....		20
Negro—Men .....	21	
Women .....	15	36
Total .....		56

CRIMES	WHITE		NEGRO		Total
	Male	Female	Male	Female	
<i>1. Against the Person</i>					
Assault and battery .....	3		12	6	21
Indecent assault .....			1		1
Wife or woman beating .....	1		2		3
<i>2. Against Property</i>					
Petit larceny .....	3		14	1	18
Petit larceny, suspected of .....	1		4		5
Trespass .....	1		3	3	7
<i>3. Against Public Order</i>					
Cruelty to animals .....				1	1
Disorderly conduct .....	6		30	27	63
Drunkenness .....	94		37	27	158
Fornication .....				2	2
Gaming .....			3		3
Gaming, keeping resort for .....			2		2
Non-support (neglect of family) .....			1		1
Street-walking .....				21	21
Vagrancy and begging .....	10		10	1	21
<i>Unclassified</i>					
Felony .....	1		4	1	6
Felony, suspected of .....			3		3
Commitments .....	120		126	90	336

TABLE 8

## Delinquent Men and Women in Jail seven times

During Period from October 1, 1910, to September 30, 1913

White—Men .....	15	
Women .....		15
Negro—Men .....	12	
Women .....	7	19
Total .....		34

CRIMES	WHITE		NEGRO		Total
	Male	Female	Male	Female	
<i>1. Against the Person</i>					
Assault and battery .....			5	1	6
Wife or woman beating .....			2		2
<i>2. Against Property</i>					
Petit larceny .....	2		13	5	20
Petit larceny, suspected of .....	2		3	2	7
Trespass .....	1		1	1	3
<i>3. Against Public Order</i>					
Carrying concealed weapon .....			3	1	4
Cruelty to animals .....					1
Disorderly conduct .....	9		9	11	29
Drunkenness .....	82		25	9	116
Fornication .....			1	2	3
Gaming .....			2		2
Selling liquor without license .....	1				1
Street-walking .....				12	12
Vagrancy and begging .....	6		13	2	21
<i>Unclassified</i>					
Felony .....	1		6	1	8
Felony, suspected of .....			1	2	3
Commitments .....	105		84	49	238

TABLE 9

## Delinquent Men and Women in Jail eight times

During Period from October 1, 1910, to September 30, 1913

White—Men .....	9	
Women .....	0	
		9
Negro—Men .....	8	
Women .....	7	
		15
Total .....		24

CRIMES	WHITE		NEGRO		Total
	Male	Female	Male	Female	
1. <i>Against the Person</i>					
Assault and battery .....	1		15	4	20
2. <i>Against Property</i>					
Petit larceny .....			13	1	14
Petit larceny, suspected of .....	2				2
Trespass .....			2	2	4
3. <i>Against Public Order</i>					
Carrying concealed weapon .....			3		3
Cruelty to animals .....			2		2
Disorderly conduct .....	3		13	19	35
Drunkenness .....	59		6	13	78
Fornication .....				2	2
Gaming .....			4	1	5
Gaming, keeping resort .....			1		1
Non support (neglect of family) .....			1		1
Street-walking .....				11	11
Vagrancy and begging .....	6		1	1	8
<i>Unclassified</i>					
Felony .....	1		3	1	5
Felony, suspected of .....				1	1
Commitments .....	72		64	56	192



TABLE 10

## Delinquent Men and Women in Jail nine times

During Period from October 1, 1910, to September 30, 1913

White—Men .....	4	
Women .....	1	5
Negro—Men .....	12	
Women .....	4	16
Total .....		21

CRIMES	WHITE		NEGRO		Total
	Male	Female	Male	Female	
<i>1. Against the Person</i>					
Assault and battery .....	1		15	4	20
Wife or woman beating .....			5		5
<i>2. Against Property</i>					
Petit larceny .....	1		8		9
Trespass .....	1		2	2	5
<i>3. Against Public Order</i>					
Carrying concealed weapon .....			2		2
Cruelty to animals .....			3		3
Disorderly conduct .....	4		19	11	34
Drunkenness .....	27	9	40	16	92
Fornication .....			1		1
Gaming .....			4		4
Street-walking .....				2	2
Vagrancy and begging .....	2		4		6
<i>Unclassified</i>					
Felony .....			4		4
Felony, suspected of .....			1	1	2
Commitments .....	36	9	108	36	189

TABLE 11

## Delinquent Men and Women in Jail ten times

During Period from October 1, 1910, to September 30, 1913

White—Men .....	10	
Women .....	1	11
Negro—Men .....	6	
Women .....	4	10
Total .....		21

CRIMES	WHITE		NEGRO		Total
	Male	Female	Male	Female	
<i>1. Against the Person</i>					
Assault and battery .....			10	2	12
Wife and woman beating .....	2		1		3
<i>2. Against Property</i>					
Petit larceny .....			6	1	7
Petit larceny, suspected of .....	1		4	3	8
Trespass .....	2		2	2	6
<i>3. Against Public Order</i>					
Carrying concealed weapon .....				1	1
Disorderly conduct .....	12		18	10	40
Drunkenness .....	72	8	8	6	94
Fornication .....		1		1	2
Gaming .....			7		7
House of ill-fame, keeping .....		1			1
Selling liquor without license .....			1		1
Street-walking .....				7	7
Vagrancy and begging .....	11			5	16
<i>Unclassified</i>					
Felony .....			2	1	3
Felony, suspected of .....			1	1	2
Commitments .....	100	10	60	40	210

TABLE 12

## Delinquent Men and Women in Jail eleven times

During Period from October 1, 1910, to September 30, 1913

White—Men .....	6	
Women .....	1	7
Negro—Men .....	3	
Women .....	3	6
Total .....		13

CRIMES	WHITE		NEGRO		Total
	Male	Female	Male	Female	
<i>1. Against the Person</i>					
Assault and battery .....			1	1	2
Wife or woman beating .....			1		1
<i>2. Against Property</i>					
Pettit larceny .....			3	3	6
Pettit larceny, suspected of .....			1		1
Trespass .....				1	1
<i>3. Against Public Order</i>					
Disorderly conduct .....	1		6	9	16
Drunkenness .....	59	11		3	73
Fornication .....				1	1
Gaming .....			7		7
Selling liquor without license .....			1	1	1
Street-walking .....				15	15
Vagrancy and begging .....	6		12		18
<i>Unclassified</i>					
Felony .....			1		1
Commitments .....	66	11	33	33	144

TABLE 13

**Delinquent Men and Women in Jail twelve times**

*During Period from October 1, 1910, to September 30, 1913*

White—Men .....	2	
Women .....	0	
		2
Negro—Men .....	1	
Women .....	2	
		3
Total .....		5

CRIMES	WHITE		NEGRO		Total
	Male	Female	Male	Female	
<i>Against Property</i>					
Petit larceny .....			4	1	5
<i>Against Public Order</i>					
Carrying concealed weapon .....			1		1
Cruelty to animals .....			1		1
Disorderly conduct .....			4	3	7
Drunkenness .....	23		1	5	29
Gaming .....			1		1
Street-walking .....				11	11
Vagrancy and begging .....	1			1	2
<i>Unclassified</i>					
Felony .....				3	3
Commitments .....	24		12	24	60

TABLE 14

**Delinquent Men and Women in Jail Thirteen times**

*During Period from October 1, 1910, to September 30, 1913*

White—Men .....	2	
Women .....	0	
		2
Negro—Men .....	2	
Women .....	0	
		2
<b>Total .....</b>		<b>4</b>

CRIMES	WHITE		NEGRO		Total
	Male	Female	Male	Female	
<i>1. Against the Person</i>					
Assault and battery .....			4		4
Wife or woman beating .....	1				1
<i>2. Against Property</i>					
Petit larceny .....			5		5
<i>3. Against Public Order</i>					
Carrying concealed weapon .....			1		1
Disorderly conduct .....			6		6
Drunkenness .....	22		5		27
Fornication .....			1		1
Gaming .....			1		1
Vagrancy and begging .....	3		3		6
<b>Commitments .....</b>	<b>26</b>		<b>26</b>		<b>52</b>



TABLE 15

Delinquent Men and Women in Jail fourteen to twenty-four times

During Period from October 1, 1910, to September 30, 1913

White—Men .....	10	
Women .....	0	10
Negro—Men .....	3	
Women .....	0	3
Total .....		13

CRIMES	WHITE		NEGRO		Total
	Male	Female	Male	Female	
<i>1. Against the Person</i>					
Assault and battery .....	4		5		9
Wife or woman beating .....			2		2
<i>2 Against Property</i>					
Petit larceny .....	5		3		8
Petit larceny, suspected of .....	1				1
<i>3. Against Public Order</i>					
Disorderly conduct .....	19		9		28
Drunkenness .....	123		22		145
Gaming .....			2		2
Gaming, keeping resort for .....			1		1
Selling liquor without license .....			1		1
Vagrancy and begging .....	19		1		20
<i>Unclassified</i>					
Felony, suspected of .....	1				1
Commitments .....	172		46		218

TABLE 16

Table showing analysis of crimes for which repeaters were committed

CLASSIFICATION	WHITE		NEGRO		Total
	Male	Female	Male	Female	
1. Crimes against the person .....	47	.....	351	61	459
2. Crimes against property .....	92	1	416	84	593
3. Crimes against public order .....	1,264	52	1,626	676	3,618
Felony .....	16	.....	163	21	200
Felony, suspected of .....	6	.....	43	15	64
Totals .....	1,425	53	2,599	857	4,934

Percentages

	Class 1 Per Cent.	Class 2 Per Cent.	Class 3 Per Cent.	Felony Per Cent.	Susp. Fel. Per Cent.
White—Male .....	10.	15.5	34.	8.	10.
Female .....	.....	00.17	00.15	.....	.....
Negro—Male .....	76.4	70.	47.00	80.	67.
Female .....	13.6	14.33	18.85	12.	23.

Class 1. Crimes against the person .....	9.3%
Class 2. Crimes against property .....	12. %
Class 3. Crimes against public order .....	73.4%
Felony .....	4. %
Felony, suspected of .....	1.3%

TABLE 17

Persons in Jail for Drunkenness two to eighteen times

During Period from October 1, 1910, to September 30, 1913

White—Male .....	203	
Female .....	6	
		209
Negro—Male .....	97	
Female .....	40	
		137
		346

TIMES	WHITE		NEGRO		Total
	Male	Female	Male	Female	
2.....	84	1	50	17	152
3.....	36	2	24	7	69
4.....	15		12	9	36
5.....	16		6	3	25
6.....	13		1	1	15
7.....	14		2	1	17
8.....	3	1		1	5
9.....	2	1	1		4
10.....	6			1	7
11.....	7	1			8
12.....	3				3
13.....	2				2
15.....	1		1		2
18.....	1				1
<b>Total</b> .....	208	6	97	40	346

Total commitments for above persons..... 1,333  
 Or, 82.4% of total commitments for drunkenness in repeaters' cases (1,618).

TABLE 18

**Persons in Jail for Petit Larceny two to five times**

*During Period from October 1, 1910, to September 30, 1913*

White—Men .....	10	
Women .....	0	
		10
Negro—Men .....	40	
Women .....	3	
		43
<b>Total .....</b>		<b>53</b>

TIMES	WHITE		NEGRO		Total
	Male	Female	Male	Female	
2 .....	8	.....	29	1	38
3 .....	1	.....	6	2	9
4 .....	1	.....	4	.....	5
5 .....	.....	.....	1	.....	1
<b>Total .....</b>	10	.....	40	3	53

Total commitments for above persons..... 128  
 Or 35% of total commitments for petit larceny in repeaters' cases.... 364

TABLE 19

**Women in Jail for Street-walking two to ten times**

*During Period from October 1, 1910, to September 30, 1913*

White .....	1
Negro .....	32
<b>Total .....</b>	<b>33</b>

TIMES	White Female	Negro Female	Total
2.....	1	14	15
3.....		8	8
4.....		4	4
5.....		2	2
6.....		3	3
10.....		1	1
<b>Total.....</b>	<b>1</b>	<b>32</b>	<b>33</b>

Total commitments for above persons.....108 or 71%

Total commitments for street-walking in repeaters' cases.....151



TABLE 20

### Punishment meted to repeaters as per Police Court Dockets and Order Books of the Hustings Court

From October 1, 1910, to September 30, 1913

NATURE OF PUNISHMENT	WHITE		NEGRO		Total	Per Cent.
	Male	Female	Male	Female		
<i>Committed to jail</i>						
In default of fine and surety...	398	19	1,454	604	3,475	60
In default of fine only.....	30	1	125	33	189	3
In default of surety only.....	890	33	532	160	1,615	28
For flat time sentence in jail..	84	.....	355	45	484	9
Total of jail prisoners proper	1,402	53	2,466	842	5,763	

Note that of jail prisoners proper 91% were committed in default of fine and surety fine only, or surety only; in other words because they owned neither money nor property. Therefore the jail became to them a debtors' prison, although imprisonment for debt has long since been adjudged illegal.

CRIMES	WHITE		NEGRO		Total
	Male	Female	Male	Female	
<i>Committed to jail pending the arrival of guards from</i>					
Virginia State Penitentiary....	2	.....	85	15	102
The public roads.....	21	.....	30	.....	51
The Negro Reformatory.....	.....	.....	18	.....	18
Total.....	23	.....	133	15	171

DEGREE OF PUNISHMENT	WHITE		NEGRO		Total
	Male	Female	Male	Female	
<i>Days to serve in jail in default of</i>					
Fine and surety.....	18,157	510	67,878	12,943	99,488
Fine only.....	543	30	4,377	1,354	6,304
Surety only.....	45,398	1,250	41,922	10,827	99,397
Flat jail sentence.....	8,439	.....	39,271	4,950	52,660
Total.....	72,537	1,790	153,448	30,074	257,849

TABLE 21

Mentality of Jail repeaters according to reactions to the Binet-Simon measuring scale for intelligence

WHITE DELINQUENTS—MALE AND FEMALE							
MENTAL AGE	CHRONOLOGICAL AGE						Total
	Under 21	21-30	31-40	41-50	51-60	61-70	
7.....		1			1		2
8.....	1	4	2		2		9
9.....		3	3	1			7
10.....		2	2			1	5
11.....		1			1		2
Normal.....	1	6	10	7	1		25
Totals.....	2	17	17	8	5	1	50

Feeble-minded.....50%

NEGRO DELINQUENTS—MALE AND FEMALE							
MENTAL AGE	CHRONOLOGICAL AGE						Total
	Under 21	21-30	31-40	41-50	51-60	61-70	
7.....		2	3		1		6
8.....		2	6	1	2		11
9.....		1	5		1		7
10.....			7	1	1	1	10
11.....		2	3				5
Normal.....			7	3	1		11
Totals.....	7	31	5	6	1		50

Feeble-minded.....78%

Total feeble-minded, white and negro.....64%

REPEATERS IN DRUNKENNESS								
MENTAL AGE	7	8	9	10	11	Normal	Total	Per Cent F. M.
White men and women..	2	4	5	3	1	19	34	44.0
Negro men and women..	1	5	3	4	1	2	16	87.5

Total feeble-minded.....58%

REPEATERS IN CRIME								
MENTAL AGE	7	8	9	10	11	Normal	Total	Per Cent F. M.
White men and women ..		5	2	2	1	6	16	62.5
Negro men and women ..	5	6	4	6	4	9	34	78.5

Total feeble-minded.....70%

# Chapter X.

## SUMMARY

### *The Evil*

1. Where both parents are mentally defective, feeble-mindedness is inherited not only by one child, but by all the children in the family. Approximately, 80% of feeble-mindedness is hereditary.

2. Insanity, epilepsy and feeble-mindedness occur not only in the same individual, but in the same families, and appear to arise from the same neuropathic make-up. By eliminating the feeble-minded, we would proportionately reduce our insane and epileptic population. It costs at least \$600,000.00 annually, exclusive of interest on the real and personal property to maintain our institutions for the insane.

3. The feeble-minded child will not respond favorably to methods ordinarily applied to normal children.

### *The Remedy*

1. Prevent by segregation or sterilization the procreation of the feeble-minded. Do this and most of them could be eliminated in two generations.

Only by striking at the fountain head, i. e., by segregating or sterilizing all feeble-minded child-producers, can we hope to dry up the springs of this evil.

2. Segregate the feeble-minded. Take them back to nature and let them earn their own support and save the State the three million dollars or more they are now costing, directly or indirectly.

3. As a means of detecting the feeble-minded in institutions for children, all children should be tested with the Binet scale, upon admission, their history carefully studied, and if found to be backward they should be placed in classes for backward children; and should subsequent reactions demonstrate them to be feeble-minded, then they should be sent to the colony for the feeble-minded.

4. Virginia spends nearly two and one-half millions a year in charity, including almshouse, public outdoor relief and private donations. Much of this money is being used to perpetuate poverty. Our almshouses are virtually lying in hospitals for feeble-minded women. In some of our almshouses certain feeble-minded families have lived and propagated their kind for six and seven generations.

Fully 80% of all persons in our almshouses are feeble-minded.

\$1,141,210.00 is tied up in almshouse real estate. The cost per capita of maintenance is \$184.86. The almshouse is not only *not* a suitable institution for the feeble-minded, but is a far more expensive one than a colony for the feeble-minded would be.

5. A large number of persons receiving volunteer and public outdoor relief are feeble-minded, or are burdened with feeble-minded relatives, and indiscriminate charity encourages such persons to live at large and propagate their kind. Outdoor relief authorities and organized charities are not equipped to handle the feeble-minded.

6. Sixty-eight per cent. of the children who pass through the juvenile courts and are found in the industrial schools are apparently feeble-minded, and, as such will never respond to methods ordinarily applied to normal delinquents, and if thrown out on the world to shift for themselves will be the criminals of to-morrow.

7. Jail prisoners are our greatest prison problem; they live in enforced idleness while the taxpayer

4. The daily population of our almshouses is 2,000, of whom 1,600 are feeble-minded. Place the 1,600 feeble-minded in a State institution where they can be cared for more economically and where they will not be allowed to propagate their kind, the counties to pay pro rata for their support.

In a colony for the feeble-minded many of the almshouse inmates could be made self-supporting, and all the children except idiots could be trained to earn their own support.

5. Whenever and wherever found the feeble-minded should be recognized as such, and segregated where they will not be able to menace the public welfare and increase the taxpayer's burden.

6. Children should be tested with the Binet scale in the public schools and courts, and classes established for backward children, both in the schools and reformatories. The feeble-minded child should be segregated and trained to earn his living.

7. We should pay more attention to cases of young offenders, first offenders, and petty offenders. The

works to support them at an annual cost of nearly \$400,000.00. Over 60% of the jail population is made up of feeble-minded and other permanently anti-social persons who practically live in jail all the time, and will burden the taxpayer either in jails or other institutions with themselves and families as long as they live.

The jail neither reforms prisoners nor, as a rule, deters them from a repetition of delinquency.

8. By examination of a segregated district in a certain Virginia city, 71.6% of prostitutes plying their trade were found to be feeble-minded, which has been confirmed by investigations of the family history, etc., of these women.

Not less than a million dollars is worse than thrown away in Virginia in prostitution every year, and the prostitute in the bawdy house and in the street is the center for the spread of venereal disease.

background of each case should be studied, and punishment should take into consideration both the good of the individual and the weal of society. This class of offenders should be tried on probation and left in freedom conditioned upon good behavior and in cases of fines, they should be allowed to pay in instalments.

As the jail system is wrong socially and economically, it should be abolished, and there should be established in its stead a State farm for defective delinquents, and city farms for ordinary short-term prisoners. Both classes can be made self-supporting, which would result in saving the State more in one year than the cost of purchasing and equipping a farm the size of the District of Columbia prison farm.

8. Society should provide for these women, and not punish them for doing that which their heredity made almost sure; they should be segregated where they can be protected against licentious men and bad, avaricious women, where they cannot harm others and may, in a measure, redeem themselves.



# Chapter XI.

---

## A Plan for the Training, Segregation and Prevention of the Procreation of the Weak-minded.

### *Scheme 1.*

It is suggested:

1. That the protection of the State be extended to all persons who cannot take a normal part in the struggle of life owing to mental defect. Heretofore, State care has been extended to only those (save about fifty feeble-minded women of child-bearing age) who have been declared insane or epileptic by a commission. We suggest that hereafter all who are incapable, from mental defect, of managing their own affairs be placed under State supervision and control, unless satisfactorily cared for by parent or guardian.

This is not an entirely new idea with us, for already we have the germ of it in that we have established at Madison Heights a colony to which we have been committing the worst cases of feeble-minded women of child-bearing age. The rest of the dependent or delinquent feeble-minded, not cared for satisfactorily by parents or guardians, are being supported by the taxpayer either in almshouses or jails.

2. That the mental condition of these persons and not their poverty or their crime is the real ground for their claim for help from the State. Heretofore, many of them have been provided for by the authorities for the care of the poor, as paupers, or they have been dealt with as criminals on account of their violation of the law. We propose that hereafter they be dealt with primarily on the ground of their mental defect.

This is based on justice too evident to require an explanation or defense.

3. That in order thus adequately to deal with the mentally defective, it is necessary to ascertain who and where they are, and to bring them into relation with those legally authorized to deal with them.

This is not an innovation. Four years ago the Legislature authorized the State Board of Charities and Corrections to find and register the mental defectives in the State. This has been done so far as the Board was able to do it under existing laws.

4. That the marriage of mental defectives should be prohibited by law.

5. That pronouncedly defective persons in the custody of State authorities, and other defectives that parents or guardians wish sterilized, should be thus dealt with.

The superintendents of the hospitals for the insane, and the members of the General Board have been for years unanimous in the opinion that the marriage of mental defectives should be prohibited by law, and that there should be a law authorizing the sterilization of such persons.

6. That the protection of mentally defective persons, whatever form it may take, be continued so long as it is necessary for their good. This is

desirable not only in the interest of mental defectives, but also in the interest of the community. It follows that the State should have authority to segregate and to detain mentally defective persons under proper conditions and limitations.

This is in the nature of an indeterminate sentence, and is at the basis of the law which provides that the superintendent of the Virginia Colony for the Feeble-minded shall have authority to hold mentally defective persons as long as he pleases, and discharge such persons when he pleases, resting upon the principle that the protection of mental defectives shall be continued as long as it is deemed necessary for their good.

7. That in order properly to supervise private institutions and to provide adequately for the safety of all mentally defective persons and likewise to protect the community, a central authority is indispensable.

Therefore, it is proposed that the State Board of Charities and Corrections be empowered as follows:

(a) To have charge of the registration of the mentally defective persons of the Commonwealth.

(b) To have supervision of the care of such persons pending admission to institutions.

(c) To have power to enforce the law for the protection of the mental defective in the community.

(d) To have authority to supervise private institutions for the care and training of the feeble-minded.

(e) To encourage research into the medical, social, and economic relations of mental deficiency.

(f) To have supervision of the deportation and removal of non-residents who are mentally defective.

The State Board of Charities and Corrections is suggested as the central authority for reasons of economy and to avoid a multiplication of boards.

#### *How the Work Should Be Conducted.*

The work of the State care of the feeble-minded in Virginia should be divided into two departments:

#### **The Home Department, and The Institutional Department.**

*The Home Department.*—Whenever a child, not delinquent, neglected or dependent, is declared feeble-minded, the parent or guardian of such child should be notified and given instructions as to the menace of feeble-mindedness to the child, the family and the community, and as to how to care for said child. All correspondence and advice in this connection should be confidential.

Said parents or guardians should have the right to elect whether the mental defective shall be allowed to remain in the home or be committed to an institution. And if the child is to remain in the family, said parent or guardian should be given rules for the care and training of the feeble-minded, prepared by the State Board of Charities and Corrections.

When a child in the custody or under the supervision of the State Board of Charities and Corrections reaches the age of twenty-one years and is, in the opinion of the said board, feeble-minded, said child should be taken before the judge of the circuit court of the county or city in which he resides, in vacation, and if, in the opinion of the court he is feeble-minded, the court should have authority to commit him to the said State Board of Charities and Corrections, or to send him to a suitable institution.

The Board of Charities and Corrections should have authority to place in family homes any destitute feeble-minded person who, in the opinion of the court, could be so placed without danger to the child, the home, or community. The rules and regulations governing the feeble-minded committed to parents or guardians should apply in all cases of destitute feeble-minded persons placed in homes, and such persons should be regarded by the law as minors, according to their mental and not their physical age.

The Home Department has for its guidance these principles: First, That the parents or guardians of a feeble-minded child have a right to the control of the child until it becomes dangerous or burdensome to the community; Second, That the State has not the right to interfere in this control on the ground that the child is a mental defective, but only on the basis that the child is being so neglected that it is in danger of becoming a burden to the community, or so incorrigible as to become a menace to the community's welfare; i. e., the State has a right to interfere in the control of a child only when such child is dependent, neglected, or delinquent.

In regard to advising with the parents or guardians of feeble-minded children, this is suggested on the principle that just as it is deemed wise and right for a physician to discuss, confidentially, with a parent or guardian the physical condition of a child, and just as the schools having medical inspection and employing nurses should report to the parent or guardian as to the child's physical condition, even so the State Board of Charities and Corrections or the State Board of Mental Deficiency should report, confidentially, to the parent or guardian when it appears that a child is a mental defective, and give instructions as to the potential danger to the family and to the community.

The provision that "When a child in the custody or under the supervision of the State Board of Charities and Corrections reaches the age of twenty-one years and is, in the opinion of said board, feeble-minded, said child should be taken before the judge of the circuit court," etc., is suggested for the protection of both the child and the community. For, although courts have the right to commit destitute and delinquent children to the Board of Charities and Corrections until they are twenty-one, yet the courts cannot legally commit such children beyond said limit—when they reach the age of twenty-one, they automatically are freed. If they are mental defectives and dangerous, or if they are inoffensive, yet incapable of protecting themselves from vicious or immoral influences, they should not be allowed to have freedom, for such freedom results in the worst kind of slavery. Hence the provision that they should at that climatic age be brought again into court.

*Institutional Department.*—The institutional department should be composed of the following institutions:

1. The public schools, with special classes for backward children.

Such classes are now being organized in the public schools. The State superintendent advises that such classes can be organized gradually in all our school districts without additional expense.

2. State school for feeble-minded and epileptic white children. Such a school is now in operation under Dr. A. S. Priddy at the Virginia Colony for Epileptics and Feeble-minded.

3. State school for feeble-minded and epileptic Negro children.

This school can be put into operation at the Central State Hospital when the appropriation for maintenance has been made.

4. State colony for white feeble-minded (already established).

5. State colony for negro feeble-minded (already established on grounds of Central State Hospital, Petersburg.)

6. Juvenile reformatories. (Which have already been established.)

7. A farm colony for defective delinquents, to which all prostitutes and street-walkers and all repeaters should be committed.

The farm colony for defective delinquents is the only new institution herein recommended. (Dr. A. S. Priddy has wisely stated that he could not handle defective delinquents in the Colony for the Feeble-minded.) The organization of such a farm is for the purpose of taking permanently anti-social persons—the repeaters and prostitutes—out of jail and placing them on this farm.

8. City farms for delinquents. (At Lynchburg one such farm has been established; the land costing \$5,000, the buildings and equipment \$5,000. Such farms are to be established by the counties and cities at their discretion, to supplant the jails eventually. As stated, the law authorizing them has already been enacted.)

The District of Columbia Prison Farm for Misdemeanants has been in operation five years. The Board of Charities and Corrections has visited and inspected the institution. The superintendent, Mr. W. H. Whittaker, says that it is more than paying expenses. He states that 75% of his inmates are feeble-minded, and that they are worth, at the least, 75c. a day, and that the actual cost per capita per diem for all expenses is 60c., so that there is a clear profit of at least 15c. a day for each prisoner, and the average sentence is 35 days.

The suggestion that men and women, now in jail for delinquency, and suspected of being feeble-minded, be placed on a farm for defective delinquents under observation for twelve months, is not a radical one. It is similar to the rule enforced in the hospitals for the insane with regard to the criminal insane.

*The Detection, Registration, Commitment, Training and Care of Defective Dependents and Delinquents.*

*Defectives in Public Schools.*—There should be organized as far as practicable, in every school district classes for backward children. (Such classes are now being organized in the cities and this work can be gradually extended as suggested without additional expense to the State.) All children, upon admission to these classes, should be given a thorough physical



and mental examination, if such examination has not already been given, and a report of such examination should be made to the State Board of Charities and Corrections. A record of the progress of each child in any such class should be kept, and a mental examination should be given at least once during the session. (See Appendix, page 120.)

Records of progress and of mental examinations should be forwarded to the State Board of Charities and Corrections, and whenever, in the opinion of the said Board and the Division Superintendent of Schools, a child has proven to be a mental defective, the said Board should have authority, in its discretion, to transfer such child to the State School for the Feeble-minded, as provided by law.

*State School for Feeble-Minded and Epileptic Children.*—The object of this school should be the manual training of defective children with a view to equipping them so that they will be self-supporting; and whenever, in the opinion of the superintendent of the school, a child has been trained sufficiently to become self-supporting he should be transferred to the colony for the feeble-minded, or placed in a home, as the law provides.

Whenever the parent or guardian of a mentally defective child is able to provide for such child in the State school for the feeble-minded, he should be required to pay an amount equal to the actual expense of care and training during the child's stay at the institution. Destitute children, however, should be received free of cost.

All children received by agencies for the care and training of destitute children should be given a physical and mental test before admission, and report of such tests should be made to the State Board of Charities and Corrections, and the said board should have the right of supervision of all such institutions. And the counties, cities or institutions committing children to the school for the feeble-minded should pay cost of maintenance, which would be less than the cost of maintenance at the county or city almshouse.

*Examination and Commitment of Children Brought into Court.*—All children under eighteen years of age, who are brought into court, should be given a mental and physical test prescribed by the State Board of Charities and Corrections; and a study of their family history should be made and a record of such test and family history filed for reference. Whenever, in the opinion of the said Board and Court a delinquent or dependent child is feeble-minded, the said Board should have authority, in its discretion, with the consent of the court to transfer such child to the school for the feeble-minded, or the State colony for the feeble-minded.

*Examination and Commitment of Adults Brought into Court.*—All persons committed to jail for violation of the laws of the State of Virginia should be examined by the court as to their family, economic and school history, and the record of such examination filed in the clerk's office of the county or city, and a copy of such record forwarded to the State Board of Charities and Corrections.

All persons convicted of and sentenced to jail for a second offense should be given a mental examination prescribed by the State Board of Charities and Corrections, and if the said board believes that such person is a mental



defective, he should be transferred to the State colony for defective delinquents, and placed under observation and subjected to a mental test once in six months for a period of one year. If, at the expiration of one year the superintendent of the colony and the State Board of Charities and Corrections believe said person to be normal mentally, he should be discharged; or at the discretion of the Superintendent turned over to the proper authorities for such action as they may deem wise; if, on the other hand, the said board and superintendent are of the opinion that the person is a mental defective, he should be committed to the colony for defective delinquents on an indeterminate sentence.

*Defectives in Juvenile Reformatories.*—It is proposed that the schools at the juvenile reformatories be made schools for backward children, and that all children committed to these institutions be given a thorough physical and mental examination, and that a study be made of the family history of these children, and that a report of such examination and study of family history be forwarded to the State Board of Charities and Corrections; that a record be made of the progress of these children in the school, and that they be subjected to a mental test at least once a year; that a copy of the school records and other records of tests be forwarded to the State Board of Charities and Corrections, and said board should have authority, with the consent of the court, to transfer from reformatories to the State schools for the feeble-minded, any child who, after investigation, the State Board of Charities and Corrections, and the division superintendent of schools, believe to be mentally defective.

The foregoing plan is suggested in response to a demand that the scheme be made as inexpensive as possible. Scheme II points out a more expensive, but in the opinion of many competent judges, a better way.

#### *Scheme II.*

There are approximately 1,500 prisoners in Virginia jails every day. Say that 300 of them are awaiting trial or are to be transferred to the penitentiary, road camps, or hospitals for the insane; put the remaining 1,200 at work on farms for delinquents, as we suggest and as is being done at Occoquan and at Lynchburg, and commit, as we have suggested, the repeaters to the proposed State colony for misdemeanants, and at least \$300.00 a day will be saved; and as their labor will be worth an additional 25c. a day, the total saving would be at least \$600 a day.

The per capita cost of maintaining an average population of 2,000 paupers in almshouses is \$184 per annum—more than the insane cost in our hospitals. To provide for 1,600 feeble-minded in a colony, as we suggest, would not cost more than \$125 per capita per annum to begin with, and eventually, nearly all of the feeble-minded, except idiots, should there be made self-supporting. As the counties are now paying for the support of their feeble-minded paupers in county almshouses, they should bear the expense of maintaining them in the colony. As suggested, the almshouse real estate, which is valued at over a million dollars, if sold, could be used by the counties to pay for maintenance of feeble-minded paupers at the State Colony. Besides, these degenerate paupers would be better cared for, and would be prevented from propagating their kind.

Accordingly, there would apparently be an immediate saving of not less than \$300,000 per annum, with an ultimate reduction of degeneracy in no small degree. Certainly, therefore, it would, as a matter of economy, if this were the only consideration, be wise to spend \$10,000 per annum in the work of segregating and undertaking to reduce the number of mental defectives.

We therefore suggest, as an alternate plan: that a board composed of five members, be appointed by the Governor, with the consent of the Senate, to be known as the "State Mental Deficiency Board," and that there be conferred upon said board all the duties and powers suggested in plan number one; that the board be authorized to appoint an executive secretary, and that the Register of the Land Office be instructed to furnish the board an office; and that the sum of ten thousand dollars per annum be appropriated for the maintenance of said office.

That the "State Mental Deficiency Board" be authorized to investigate and report upon the question of the advisability of establishing a separate State institution for the feeble-minded with colonies for the several grades of patients and schools for defective children.

*Distribution of Feeble-Minded Persons Reported to the State Board of Charities and Corrections*

*Housed in Unsuitable Institutions*

In State hospitals for the insane.....	462
In county and city almshouses.....	676
In reformatories, one jail and the penitentiary.....	527
In orphanages and children's agencies .....	153

*At Large*

Reported by physicians and ministers .....	2,496
Helped by overseers of the poor .....	385

*In Suitable Institutions*

Miss Gundry's Private School, Falls Church, Va. ....	20
Virginia Colony for the Feeble-minded .....	70

---

Total .....	4,789
-------------	-------

# APPENDIX.

## The Public Schools and the Abnormal Child

By K. J. HOKE,

*Second Assistant Superintendent Richmond Public Schools.*

One of the criticisms which is often leveled against the Public School System of the United States is that the instruction is too mechanical; that the public schools tend to treat all children as if they were alike, both physically and mentally. The tendency in modern education to reach the individual needs of the children should meet this objection. The administrators of our public schools are demanding that the instruction in the class-room be made more and more individual, that the teacher shall plan her instruction to reach the individual child instead of planning it to be presented to a large number of children at once, and assuming that all will profit alike from it.

In following out this principle of instruction, one of the natural consequences has been that students of education are beginning to know more of the individual abilities of children and are planning instruction to train them accordingly. In this movement the psychologists are leading the way and are providing much information that serves as a basis for more scientific treatment of children. This information shows the wide range of abilities existing among children of the same class in spite of the fact that they have been so placed on the assumption that they were of the same ability. The following figures show the wide range in ability to add correctly in eight (8) minutes a certain number of addition examples in a 4A grade in the public schools of the city of Richmond:

No. children.	No. examples right.
2	9
1	7
1	6
1	5
2	4
6	3
1	2
2	1
3	0

A further illustration of this principle is shown by the following figures which give the different mental ages according to the Binet-Simon Scale in a 3B grade of the same school system:

No. children.	Mental ages.
3	8
5	9
20	10
8	11
1	12

Since this wide range of ability exists among children of a single class, manifestly it is the function of the public schools to determine its extent. If a school system attempts this problem, what means are available for its solution?

In the first place, the grade and the chronological age of the child should always be available. When this information is arranged in a table form, it enables the teacher to locate the child which has fallen behind in its grade. The following table is given to illustrate this point:

Grade	CHRONOLOGICAL AGES								
	7	8	9	10	11	12	13	14	15
1A .....			5	6					
1B .....			2	3	2	1	2	1	
2A .....			1	2	4				
2B .....				4	7	3	1	2	
3A .....					4	5	2		
3B .....					3	3	2	3	1

The normal ages for the different grades are as follows: 1A and 1B grades, 7 years; 2A and 2B grades, 8 years; 3A and 3B grades, 9 years. All of these children are above these ages.

After the child is located in the grade, the next source of information is the cumulative record which gives its progress in school. If a child is promoted at the end of each term, it would complete the elementary schools in 7 years, and its progress will be shown by the accompanying record card which is the history of a child's progress in the Richmond Public Schools (see illustration No. 1).

This child entered the 1A grade in September, 1906. In February, 1907, it was promoted to the 1B grade, and so on throughout its entire school life. If a child is not promoted each term, its record card will show a different progress. The accompanying record shows that the child spent 8 terms or 4 years in the 1A grade and 3 terms or 1½ years in the 1B grade when it was taken into the ungraded class. At that time it was 15 years and 9 months old, had been in school 5½ years, and had completed the work of *one year only* (see illustration No. 2).

The progress of still another child is given to illustrate further the fact that there are certain children who cannot profit by the illustration given

to the normal child. This child spent 3 terms or 1½ years in the 1A grade, 4 terms or 2 years in the 1B grade, 3 terms or 1½ years in the 2A grade, and was still in the 2B grade at the age of 15 years. It had been in school 5½ years and had completed only 1½ years of work. (See illustration No. 3.)

	Sept 19 06	Feb 19 07	Sept 19 07	Feb 19 08	Sept 19 08	Feb 19 09	Sept 19 09	Back Feb 19 10	Sept 19 10	Feb 19 11	Sept 19 11	Feb 19 12	Sept 19 12	Feb 19 13	Sept 19 13	Feb 19 19	Sept 19 19
DATE																	
NO	1	1	2	2	3	3	4	4	5	5	6	6	7	7			
GRADE LETTER	A	B	A	B	A	B	A	B	A	B	A	B	A	B			
TERM STAND'G	A	A	A	A	A	B	B	B	B	B	B	B	B				
DEPT CLIENT														93.3%			
EX																	
ABSENT	0	9	9	3	0	10	0	0	2	0	0	0	0	0			
TARDY	0	0	0	0	0	0	0	0	0	0	0	0	0	0			
DEPT Form 30-72	14-5-1																

*Transferred to High School*

ILLUSTRATION No. 1.

	Sept 19 07	Feb 19 07	Sept 19 07	Feb 19 08	Sept 19 08	Feb 19 09	Sept 19 09	Back Feb 19 10	Sept 19 10	Feb 19 11	Sept 19 11	Feb 19 12	Sept 19 12	Feb 19 13	Sept 19 13	Feb 19 14	Sept 19 14	
DATE																		
NO		1	1	1	1	1	1	1	1	1	1	1						
GRADE LETTER		A	A	A	A	A	A	A	A	B	B	B	W.C.	W.C.	W.C.	U	U	
TERM STAND'G		b	b	b	b	b	B		B	C	C	A						
DEPT CLIENT		All	R	R	R	D <sub>n</sub>	D <sub>n</sub>	S	All	All	All		Student - poor	Handwork - fair	Spelling - poor	Spelling - poor	Spelling - poor	
EX.		<i>Entrance age 8 yrs</i>																
ABSENT		17	4	3	9		4		3	4	6	0	18	10	0	15		
TARDY		0	0	0	1		0		0	0	1	0	0	0	1	0		
DEPT Form 30-72		A	A	A	A		A		A	A	A	A	B	B	B	B		
DEPT Form 30-72		<i>5½ yrs in school + 1 grade</i>																

*years grade 7.7*

ILLUSTRATION No. 2.



DATE	Sept. 19 19	Feb. 07 19	Sept. 07 19	Feb. 27 19	Sept. 08 19	Feb. 09 19	Sept. 09 19	Back Feb. 10 19	Sept. 10 19	Feb. 11 19	Sept. 11 19	Feb. 12 19	Sept. 12 19	Feb. 13 19	Sept. 13 19	Feb. 14 19	Sept. 14 19
NO		1	1	1	1	1	1	2	2	2	2	2	2	2	2	2	2
GRADE LETTER		A	A	A	B	B	B	A	A	A	B	Ung	Ung	U.C.	U.C.	U.C.	U.C.
TERM STAND'G		C	C	B	C	C	C	B	C	C	B	C	Ung	U.C.	U.C.	U.C.	U.C.
DEPT CIENT ON		A. P J			N R	A H	A		A L	A L		A P P L	Stupid - poor	Stupid - poor	Stupid - poor	Stupid - poor	Stupid - poor
EX		Entrance age 8 yrs			Chron age 15 yrs			Mental age 6 <sup>4</sup>			Years back 8 <sup>3</sup>						
ABSENT		6	0	3	2	1	1	0	1	2	0	0	0	1	0	2	
TARDY		0	0	0	0	0	0	0	0	0	0	0	0	0	0	0	
DEPT		B	A	B	C	B	B	B	B	B	B	B	B	B	A	A	
Form 30-727, 4-5-11		5 1/2 yrs in school						1 1/2 grades									

ILLUSTRATION No. 3.

From these records the following points should be observed:

1. The constant repetition of the same grade kills a child's interest.
2. Instruction for children who cannot profit from it more readily is not economical and business-like.
3. The presence of such children in a class-room hinders the progress of children who can profit from the instruction of the grade.

The next means of determining the mental ability of children is through mental and physical tests. One of these tests which is widely used is the Binet-Simon Measuring Scale. This test, in the hands of a skillful examiner, is a helpful aid in determining a child's mental ability.

Figure 1 is a graphical representation of the results from the Binet-Simon Scale applied to all the children in the first four years of three fairly representative schools in the city of Richmond. The significant thing shown in this figure is that 19 children or 2.6% were 4 or more years mentally below their chronological age; and that 103 children or 13.8% were 2 and 3 years mentally below their chronological age. It is commonly held that children who test 3 or more years back are feeble-minded. A more liberal classification is used in Richmond, as shown in the above graph. The policy has been to place those who test four or more years back in classes of 15 children each, and those who test two and three years back in classes of 20 children each.

It is true, however, that the majority of the 2.6% are, or will become permanently mentally arrested, and even some of the 13.8%. Consequently

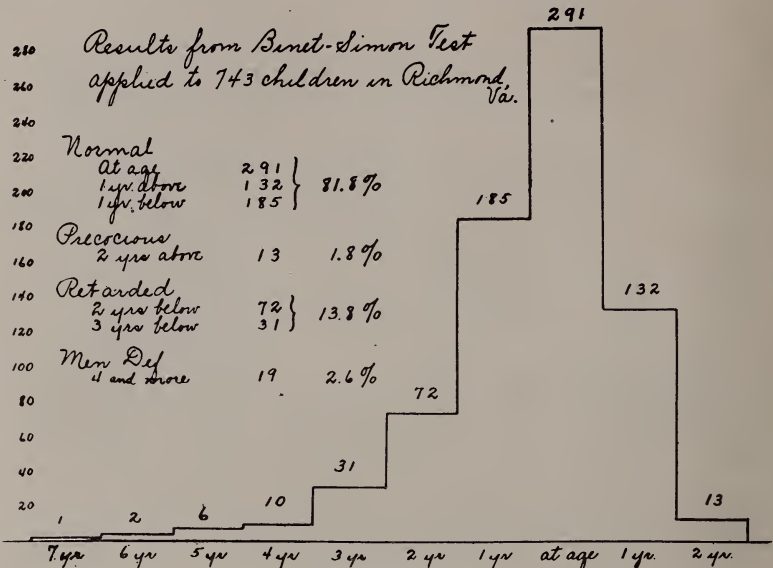

FIGURE 1.

the number of feeble-minded children in the public schools is a problem of considerable proportion.

As a usual thing, the children of the latter group can profit from the instruction given in the regular class. Most of these children have the normal amount of mentality, but have fallen behind because of late entrance, poor attendance, ill health, etc. All that is needed to place them on their feet is a little individual instruction. That these children do profit by the instruction given to the normal child is shown in Figure 2:

*Reduction in Overage of 72 children who were in 4 Special classes from Feb. to June, 1914*

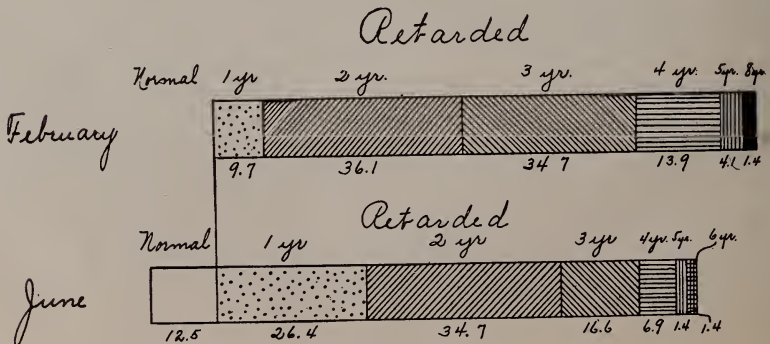

FIGURE 2.

At the beginning of the second term, 1914, there were 72 children in four classes. At that time all of these children were too old for the grades in which they were working. By June, 12.5% of them had caught up with their grades.

These classes do not differ much from the regular class except in numbers. Figure 3 shows one of these classes at work.

In some cases considerable emphasis is placed on industrial work, especially in order to arouse a child's interest. It is true, however, that some children are placed in these classes who cannot profit from the instruction given to normal children. They are the borderline cases which become permanently arrested and must be provided with instruction of a different nature.

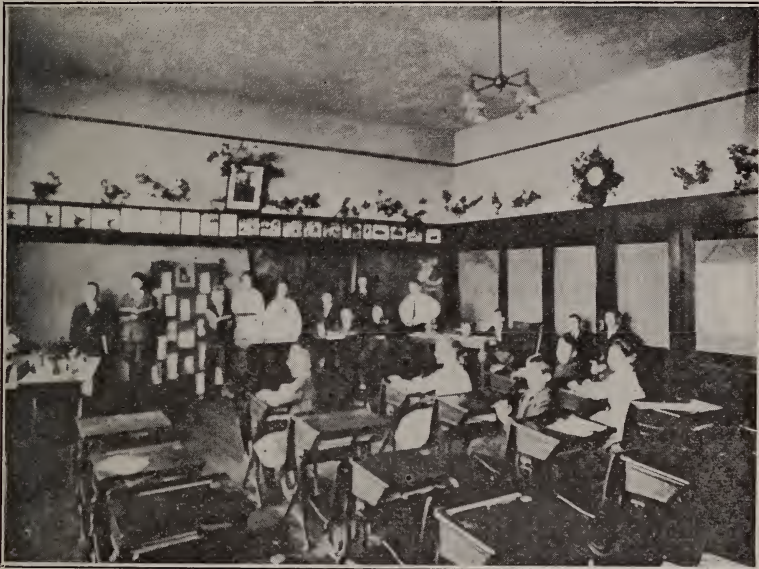

FIGURE 3.

In classes of 15 children each the mentality is much lower as represented by Figure 4, which shows that all the children are 4 and more years below, and are located at the lower extremity of the curve.

These children can profit very little from the instruction given in the regular class. In fact, few of them can read beyond the second or third reader. Progress is not expected of them from this course. Their work is almost entirely industrial and centers around mat and rug weaving, wood-work, handwork, sewing, cooking and serving meals, crochet work, gardening, etc. Their number-work, language, and reading are based on their industrial work, e. g., number-work is based on estimating the cost of their daily lunch, the amount of material in and cost of their rugs, mats, the cost of planting their garden, etc. Their language work consists in writing

the daily menu for the lunch, writing the order for the store, writing ads for sale of articles made, etc. Habits of industry, orderliness and self-control are among the big things to be taught these children. Some skill can be acquired. Interest has been aroused in this work by selling as many of the articles made as possible, and permitting the children to share in the proceeds. During the second term of the session 1914-15, one of these classes, after paying for the supplies, had about \$8.00, and another about \$12.00, for distribution to the members of the class.

At the beginning of the session 1915-16, the Richmond Public School System established a center for handling these children by combining four classes in one building. This plan offers an opportunity for better grading and more practical work. In addition, a psychological examiner has been employed to give a stated amount of time each day to a more exhaustive study of the mental and physical condition of these children. This work will be greatly facilitated by a psychological clinic which has been established by the Medical College of Virginia.

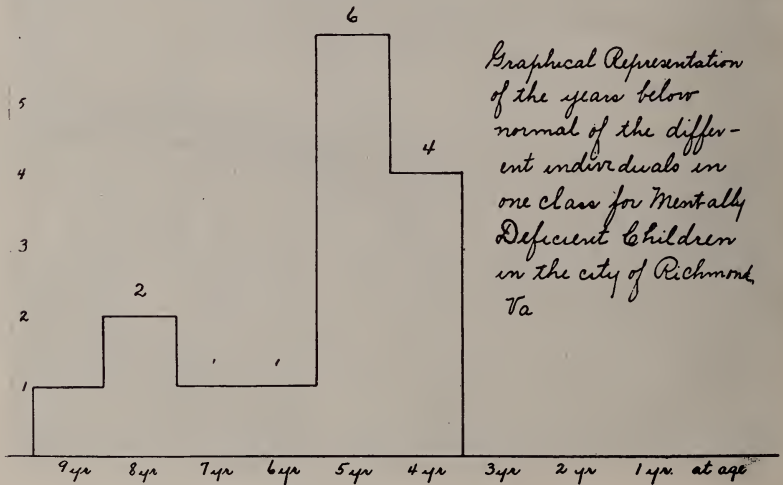

FIGURE 4.

Figure 3 shows one of these classes at work, and Figure 5 shows another at lunch.

The results from the work with the abnormal children in the city of Richmond seem to indicate that it is economical to have these children removed from the regular classes, to study them so that their mental ability can be known, and to instruct them to the extent that they can receive instruction along lines that will help them most. This policy is based on the principle that it is the inherited right of every child of school age to receive the kind and the amount of training it can profit by. To this end every modern school plant should provide means. Teachers should be trained to give the mental tests; accurate records of the progress of all children should be kept and provision should be made for the instruction



of such children in classes of not more than 15. The children of low mentality who are passing through the hands of the teacher of to-day will become the weak-minded, helpless and dangerous adults of to-morrow. What are the teachers and the administrators doing to prepare themselves to handle this problem? Surely it is a duty which they cannot evade if they are to be educators in a broad and modern interpretation of that word.

But after the public schools have located these children and placed them in ungraded classes and trained them as best they can, their work is left incomplete because the children soon reach an age when the schools cannot hold them any longer and there is no other authority to take charge of them. Consequently they go out into society to be preyed upon by and become a prey to society. It is at this point that the State should assume



FIGURE 5.

control. A central governing body, acting under special legislation, should take up the work where the schools leave off.

In the light of these facts, then, some such policy as the following seems advisable:

1. It is the duty of the public schools to study the problem presented by the child of low mentality so that the number of feeble-minded children in the community can be known.

2. It is the duty of the public schools to provide that kind of instruction for these children which will make them self-supporting citizens if they can profit by it, and so long as the home gives its share of proper supervision.



3. It is the duty of the public schools to provide instruction for feeble-minded children of school age in classes of not more than 15 children to a class.

4. It is the duty of the State to take charge of these children who are institutional cases after the public schools have exhausted their means of helping them.

By pursuing such a policy, many wards of the State would be trained to become self-supporting in a community where they are not brought in competition with the normal individual. Many of these people are passing through the hands of teachers to-day without their actual mental ability ever being known. The menace of the feeble-minded reproducing themselves would be cut off at its source.













LIBRARY OF CONGRESS



0 027 331 344 8

